

Chartered Membership Examination

Friday, 6 January 2017

Structural Engineering Design and Practice

09.30 – 13.00 and 13.30 – 17.00 (Discussion between individuals is not permitted during lunch period). A period of fifteen minutes is provided for reading the question paper immediately before the commencement of the examination. Candidates are not permitted to write in answer sheets, or on drawing paper or to use a calculator during this time. Candidates must satisfy the Examiners in ONE question.

Important

The written answer to the question selected and any A3 drawings must bear the candidate's number and the question number at the bottom of the page. Only the answer sheets supplied by the Institution may be used. The candidate's name should not appear anywhere in the script.

Notes to Candidates

1. TO PASS THE EXAMINATION, CANDIDATES MUST SATISFY THE EXAMINERS IN BOTH PARTS OF THE QUESTION ATTEMPTED.
2. Examiners will only mark work written by hand during the examination.
3. A fair proportion of marks will be awarded for the demonstration of an understanding of fundamental engineering concepts, as distinct from calculation of member forces and sizes. NOTE: In the calculation part of all questions, establishing "form and size" is taken to mean compliance with all relevant design criteria, i.e. bending, shear, deflection, etc.
4. In all questions 50 marks are allocated to Section 1 and 50 marks to Section 2.

5. The Examiners are looking for sound structural designs. It should also be remembered that aesthetics, economy and function are important in any competent engineering scheme.
6. Any assumptions made and the design data and criteria adopted must be stated.
7. Good clear drawings and sketches are required; they should show all salient and structural features to suitable scales and should incorporate adequate details.
8. Candidates will not be allowed to include any previously prepared calculations, notes, sketches, diagrams, computer output or other similar material in their answer sheets or A3 drawings. Any previously prepared information submitted by candidates will be ignored by the examiners.
9. Candidates may not bring into the examination room any electronic devices capable of wireless communication, optical photography or scanning.

The following devices are not permitted: Mobile phones, Laptops, notebooks or portable computers and similar devices, iPads, tablets and similar devices, E-readers (e.g. Kindle) and similar devices, cameras, optical scanners and similar devices.

Any candidates arriving at the examination room with such devices will be asked to switch them off and place them in a sealed bag kept by the Invigilator for the duration of the exam, which includes the lunch period.

10. This paper is set in SI Units.

Now read 'Reminder' on page 3.

Chartered Membership Examination, a reminder from your Examiners

The work you are about to start has many features in common with other examinations which you have tackled successfully but it also has some which are unusual.

As in every examination you must follow carefully the NOTES FOR CANDIDATES set out for your guidance on the front cover of this paper; allocate the available time sensibly and set out your work in a logical and clear way.

The unusual requirement of the examination is that you demonstrate the validity of the training and experience that you have acquired in recent years.

The Institution must be satisfied that you are able to bring all the various skills you are expected to possess to the effective solution of structural design problems – whether or not the problem is presented in terms that are within your actual experience.

Chartered Structural Engineers must have the ability to design and a facility to communicate their design intentions. Where you are required to list and discuss possible structural solutions you must show by brief, clear, logical and systematic presentation that you understood the general structural engineering principles involved.

In selecting and developing your design you should also remember the guidance given in the Institution's report, Structural design - achieving excellence, and in particular:

- (1) "the structure must be safe",
- (2) "a good design has certain typical features – simplicity, unity and necessity",
- (3) "the structure must fulfil its intended function".

If you have difficulty in deciding the correct interpretation of a question, pay particular attention to point 6. notes to candidates, on the front cover. The examiners will take into account your interpretation – and the design you base on this – if this is clearly stated at the beginning of your answer.

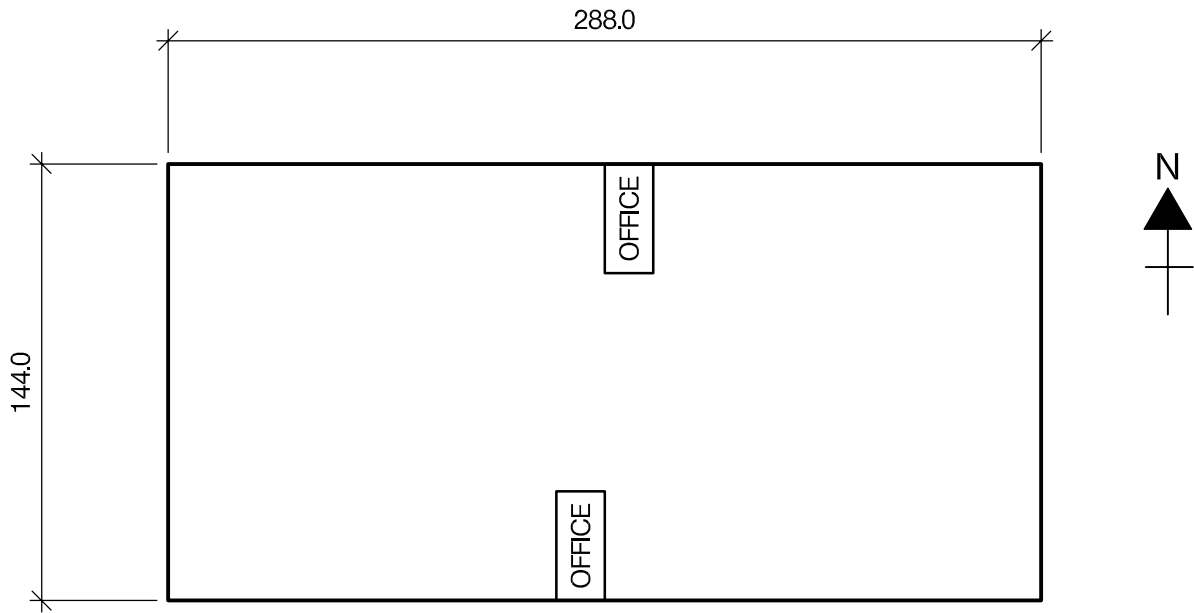

WAREHOUSE PLAN

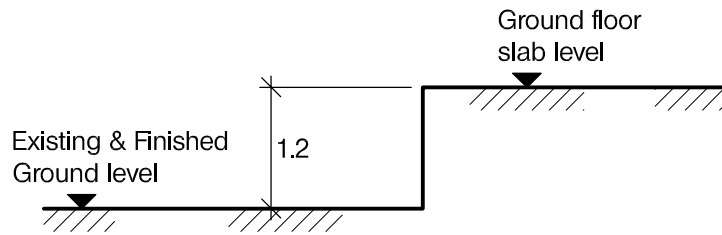

SECTION THROUGH PERIMETER OF WAREHOUSE

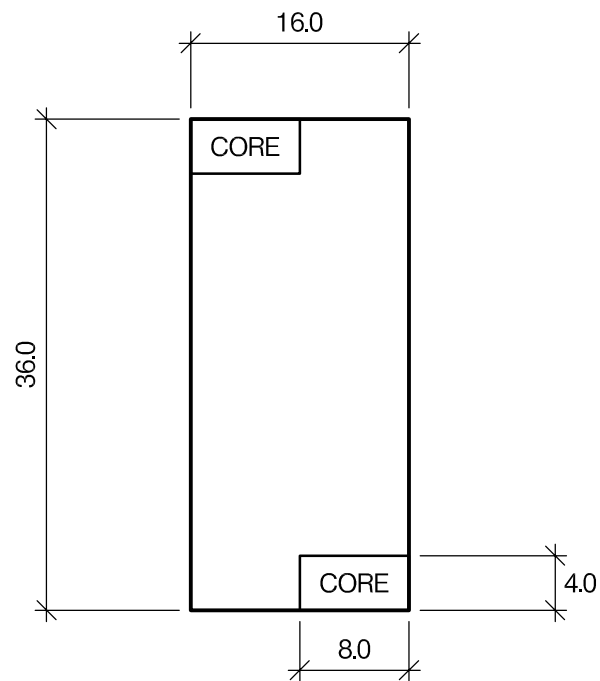

OFFICE PLAN

NOTE: All dimensions are in metres

FIGURE Q1

Question 1. Distribution Warehouse

Client's requirements

1. A large distribution warehouse with two internal offices. See Figure Q1.
2. The minimum spacing of columns within the warehouse is 16m in the East/West direction and 36m in the North/South direction. No diagonal bracing is allowed within the open area of the warehouse.
3. The minimum height clearance in the warehouse from finished ground floor level to the underside of any structure is 12m.
4. The existing site is level and the ground floor to the warehouse is to be 1.2m above the existing ground level to allow for dock levellers. The finished external ground level is to be the same as existing. The Client has available granular fill from another site to make up the level from existing ground level to the new ground finished floor level should this be required.
5. The warehouse floor is to have a high standard of levelness and flatness suitable for high lift material handling equipment.
6. The warehouse is to be clad in insulated metal cladding with a minimum roof slope of 6 degrees for drainage
7. Both of the long elevations are to accommodate 28 large doors, 56 in total, each door to have a clear width of 6m and height of 7m.
8. Within the warehouse there are to be two offices, each two storeys in height with finished floor to underside of ceiling of 3.2m and a services zone of 0.3m free from any structure.
9. The offices can have one row of internal columns with a minimum spacing of 6m.
10. The offices are to have 1 hour fire protection.

Imposed loading

- | | |
|----------------------------|-----------------------|
| 11. Warehouse ground floor | 45 kN/m ² |
| Roof | 0.6 kN/m ² |
| Services load on roof | 0.4 kN/m ² |

Office floor loading 5 kN/m² - includes allowance for ceiling, services and partitions

Site conditions

12. The site is on the edge of a town. Basic wind speed is 40m/s based on a 3 second gust: the equivalent mean hourly wind speed is 20m/s.
13. Ground conditions are constant across the site:

Ground level - 3.0m	Made ground N values vary but below 5
3.0m - 15.0m	Very soft alluvial material. C varies from 5 kN/m ² to 10 kN/m ² with two 1.0 m thick layers of peat at 6.5m and 12.5m depth
Below 15.0m	Competent Rock, allowable bearing pressure 5,000 kN/m ²

Ground water was encountered at 4.0m below ground level.

Omit from consideration

14. Detail design of the core areas within the offices.

SECTION 1

(50 marks)

- a. Prepare a design appraisal with appropriate sketches indicating two distinct and viable solutions for the proposed structure including the foundations. Indicate clearly the functional framing, load transfer and stability aspects of each scheme. Identify the solution you recommend, giving reasons for your choice (40 marks)
- b. After the design is complete the Client advises that they wish to increase the minimum spacing of internal columns in the East/West direction from 16m to 24m whilst maintaining the clear height. Also that the minimum cover to the reinforcement in the warehouse ground floor slab is to be increased to 75mm to accommodate the guide wires for automatic equipment. Write a letter to the Client explaining the effects that both these changes would have on the structure and how this request could be accommodated. (10 marks)

SECTION 2

(50 marks)

For the solution recommended in Section 1(a):

- c. Prepare sufficient design calculations to establish the form and size of all the principal structural elements including the foundations. (20 marks)
- d. Prepare general arrangement plans, sections and elevations to show the dimensions, layout and disposition of the structural elements and critical details for estimating purposes. (20 marks)
- e. Prepare a detailed method statement for the safe construction of the building and an outline construction programme. (10 marks)

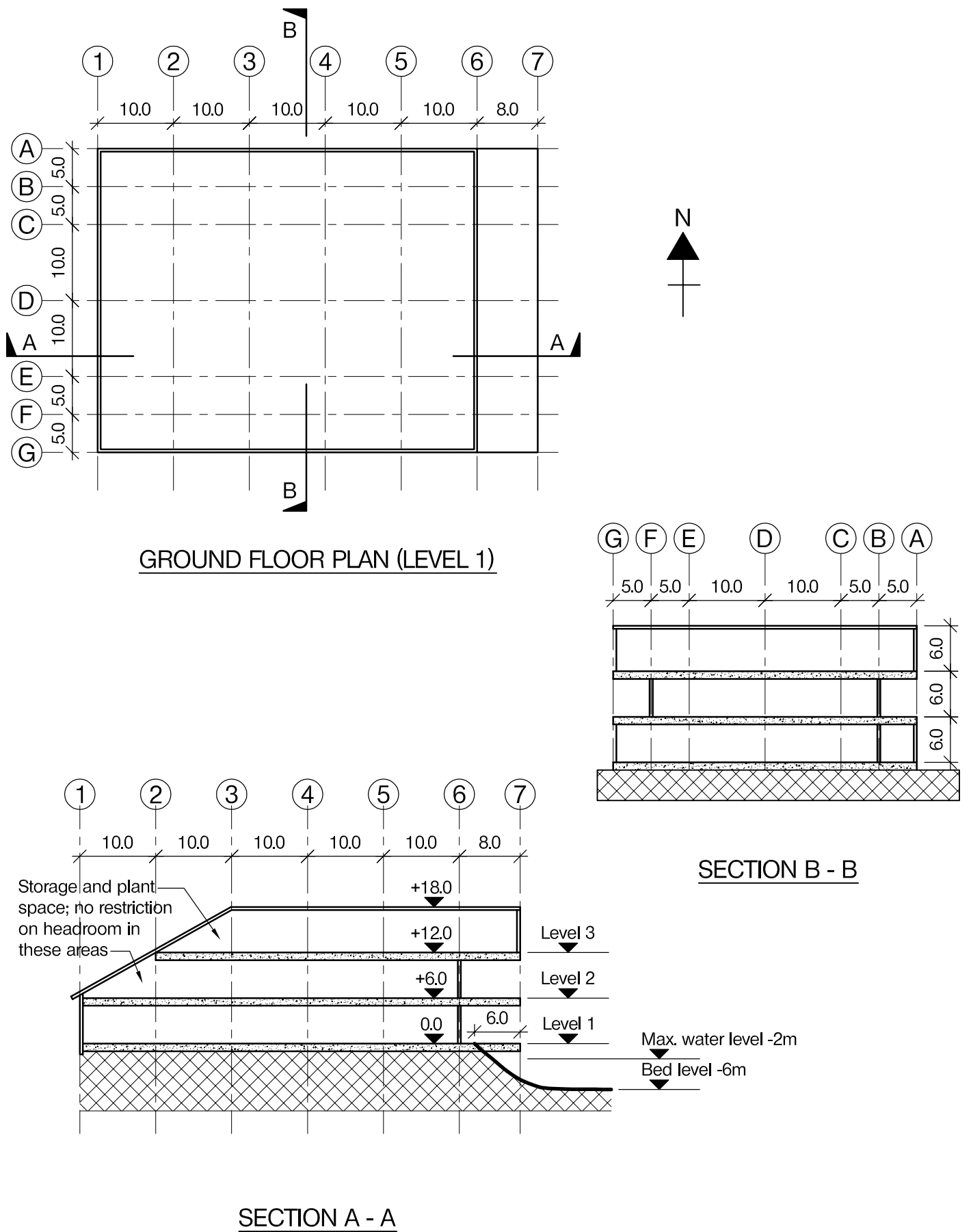

NOTE: All dimensions are in metres

FIGURE Q2

Question 2. Lakeside Development

Client's requirements

1. A new lakeside development to house a fishing club at level 1 with a café at level 2 and multiuse studio at level 3. See Figure Q2.
2. Level 1 is to cantilever over water to provide an uninterrupted platform for fishing. The café at level 2 is to have a column free covered external space to provide internal and external seating areas. All front elevations are to be 50% glazed and the remainder is to be clad in composite material with 10% glazing for windows and doors. The roof is to be of lightweight construction. The whole structure is to have a pleasant and lightweight appearance with exposed structural elements where possible.
3. The maximum overall height of the building is limited to 18.0m in order to satisfy planning requirements. The floor to floor height is to be 6.0m with a minimum clear internal height of 4.0m. A minimum service zone of 300mm is required at each level.
4. External columns are to be located within external walls, with a minimum spacing of 5.0m. Only four internal columns are permitted at each floor, if required, to achieve an economical solution.

Imposed loading

- | | |
|----------|------------------------|
| 5. Roof | 0.75 kN/m ² |
| Services | 0.25 kN/m ² |
| Floors | 5.0 kN/m ² |

Site conditions

6. The site is located on the outskirts of a large city. Basic wind speed is 48m/s based on a 3 second gust; the equivalent mean hourly wind speed is 24m/s.
7. Ground conditions are constant across the site:

Ground level - 1.0m	top soil / fill
1.0m - 2.0m	silty sandy and gravel, N=8
Below 2.0m	dense sand N=15

Ground water was encountered at 2.0m below ground level.

Omit from consideration

8. Detail design of the lift and stairs.

SECTION 1

(50 marks)

- a. Prepare a design appraisal with appropriate sketches indicating two distinct and viable solutions for the proposed structure including the foundations. Indicate clearly the functional framing, load transfer and stability aspects of each scheme. Identify the solution you recommend, giving reasons for your choice. (40 marks)
- b. After construction is complete and there has been a period of heavy rainfall, the Client realises that the initial estimated water level was inaccurate. Level 1 of the building has flooded on a number of occasions. Write a letter to the Client explaining how the building can be protected from flooding. (10 marks)

SECTION 2

(50 marks)

For the solution recommended in Section 1 (a):

- c. Prepare sufficient design calculations to establish the form and size of all the principal structural elements including the foundations. (20 marks)
- d. Prepare general arrangement plans, sections and elevations to show the dimensions, layout and disposition of the structural elements and critical details for estimating purposes. (20 marks)
- e. Prepare a detailed method statement for the safe construction of the building and an outline construction programme. (10 marks)

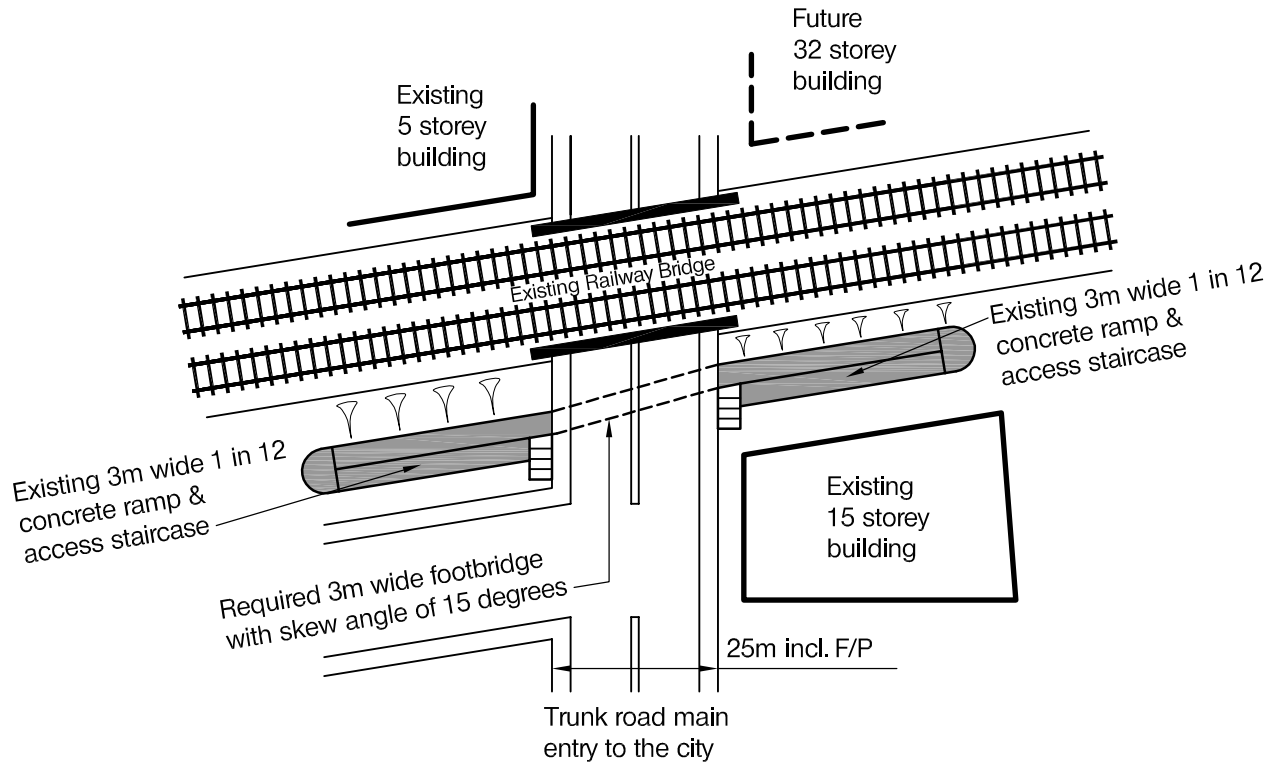

SITE PLAN

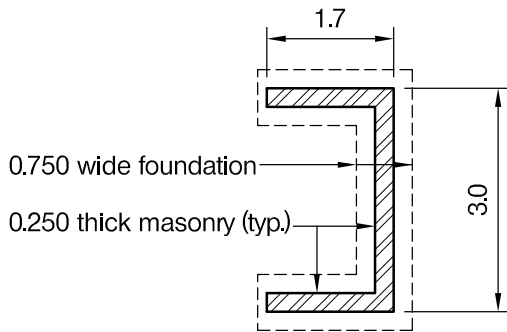

Enlarged plan of masonry abutment and its strip footing

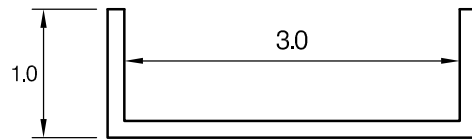

Bridge deck required dimensions

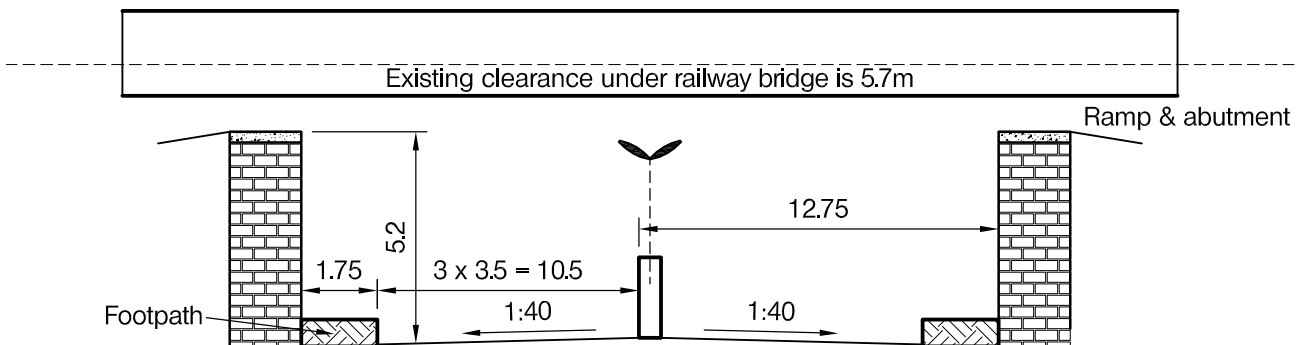

CROSS SECTION OF TRUNK ROAD IN FRONT OF EXISTING BRICK ABUTMENT & RAMP

Note: Lane next to F/P is a bus lane and 5m clearance is acceptable while other two traffic lanes must have minimum clearance of 5.4m above them.

NOTE: All dimensions are in metres

FIGURE Q3

Question 3. Replacement Footbridge

Client's requirements

1. A former simple truss footbridge has been knocked off its abutments by a vehicle passing below, damaging it beyond repair. A replacement bridge is required: see Figure Q3.
2. The footbridge crosses a main road which forms the primary route into a coastal city. The bridge must be aesthetically pleasing. It is hoped that the bridge will gain iconic status because of its high quality of design and construction.
3. The existing abutments are undamaged. They are C-shaped in plan and are formed of brickwork 250mm thick. They are seated on a mass concrete strip footing 0.75m wide: see Fig. Q3. Each abutment can carry a maximum unfactored vertical load of 450kN. The existing approach ramps are 3.0m wide and slope at 1 in 12. The minimum gap between a ramp and the adjacent railway is 5.0m.
4. The headroom requirements shown in Fig. Q3 must be strictly maintained to reduce the risk of future vehicle impacts.
5. Weekend possession of the railway may be obtained by applying 18 months in advance.

Imposed loading

6. Bridge deck: 5.0kN/m²

Site conditions

7. The site is located on the outskirts of a large city. Basic wind speed is 50m/s based on a 3 second gust; the equivalent mean hourly wind speed is 25m/s.
8. Ground conditions are constant across the site:

Ground level – 1.0m	fill
1.0m – 15.0m	sand and gravel, N = 20
below 15.0m	sandstone, safe bearing capacity 1,000kN/m ²

Ground water was not encountered.

Omit from consideration

9. Vehicle impact loading.

SECTION 1

(50 marks)

- a. Prepare a design appraisal with appropriate sketches indicating two distinct and viable solutions for the proposed structure. Indicate clearly the functional framing, load transfer and stability aspects of each scheme. Identify the solution you recommend, giving reasons for your choice. (40 marks)
- b. After the design has been completed the client discovers that a new port is being planned adjacent to the city, and the dual carriageway which the footbridge crosses will become the main access route for the port. The client decides the minimum footbridge headroom should be raised to match that of the adjacent railway bridge, 5.7m. Write a letter to the client explaining how this might be achieved. (10 marks)

SECTION 2

(50 marks)

For the solution recommended in Section 1(a):

- c. Prepare sufficient design calculations to establish the form and size of all the principal structural elements. (20 marks)
- d. Prepare general arrangement plans, sections and elevations to show the dimensions, layout and disposition of the structural elements and critical details for estimating purposes. (20 marks)
- e. Prepare a detailed method statement for the safe construction of the footbridge and an outline construction programme. (10 marks)

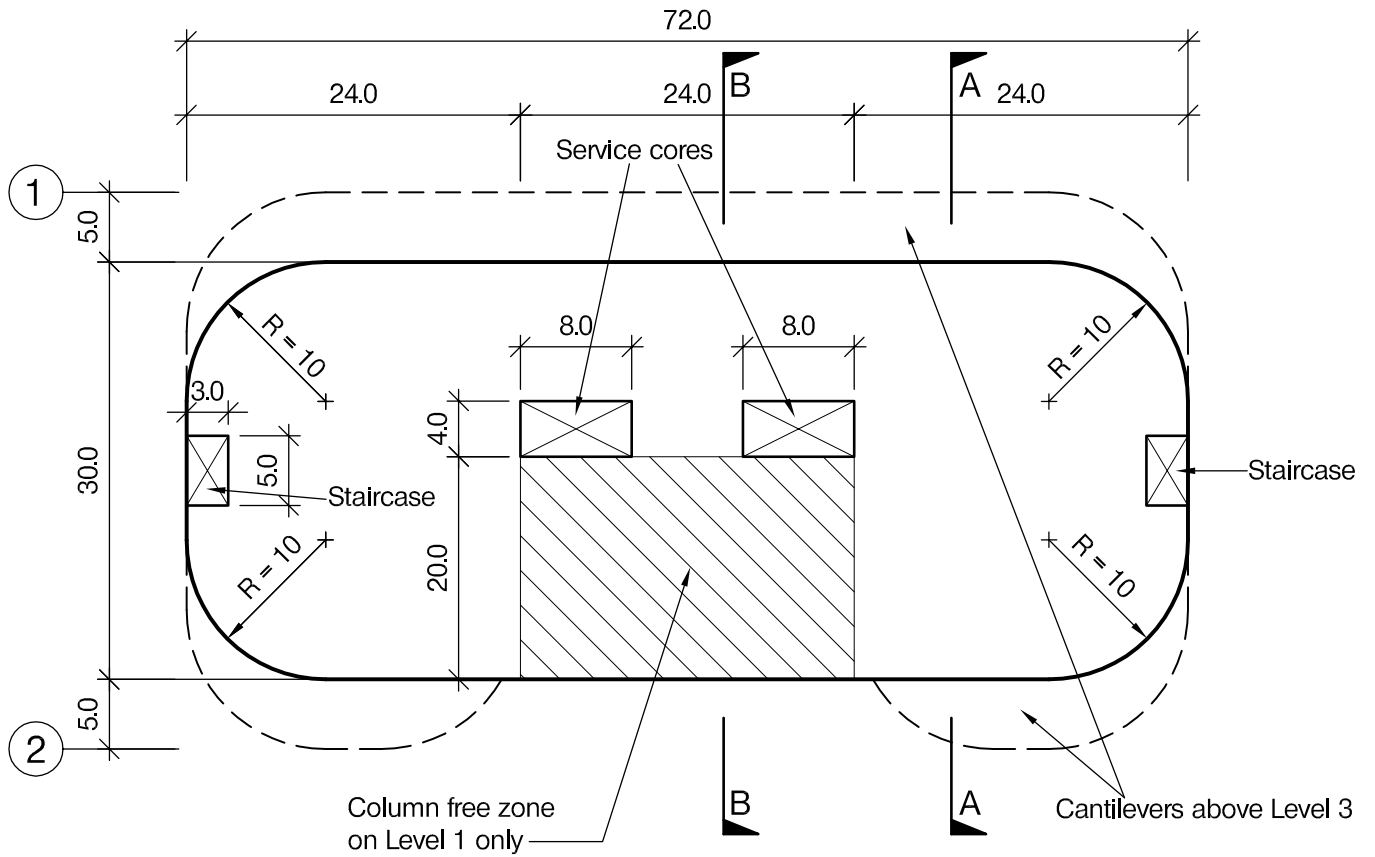

PLAN AT LEVEL 1

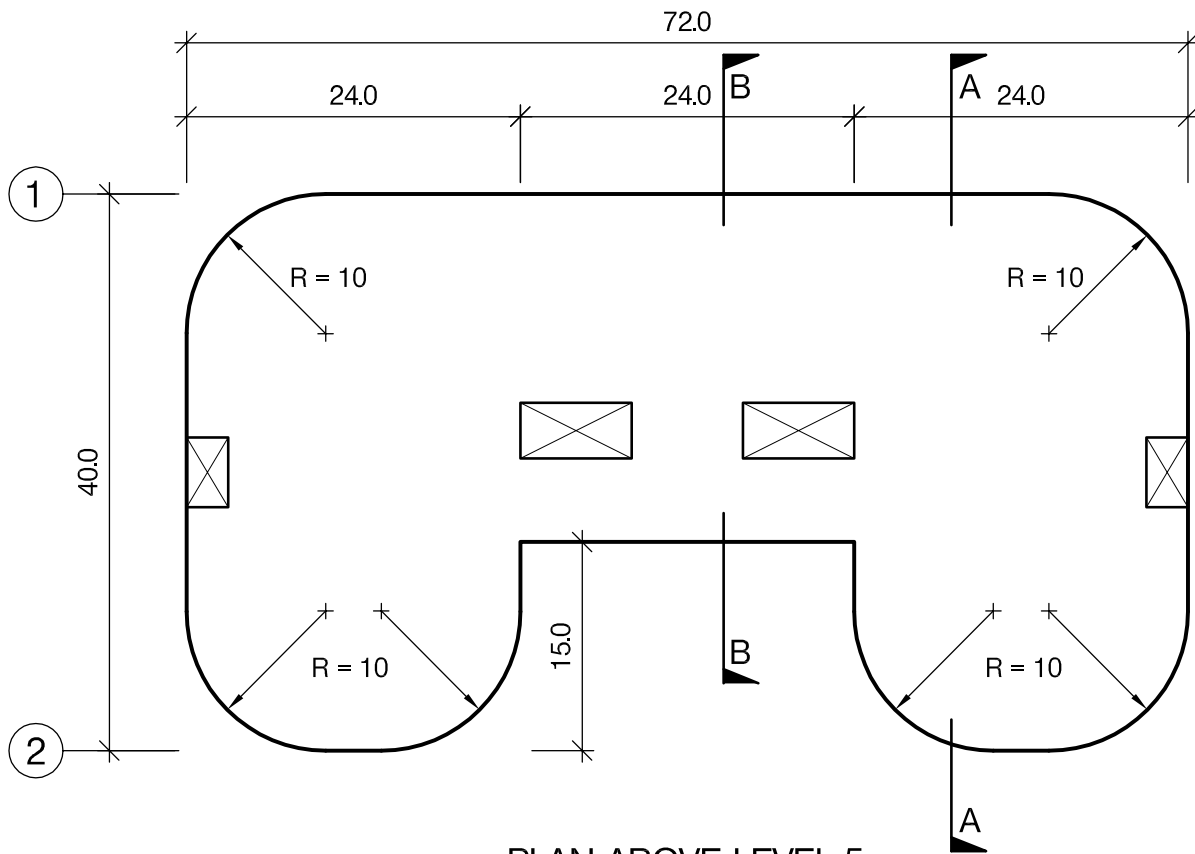

PLAN ABOVE LEVEL 5

NOTE: All dimensions are in metres

FIGURE Q4 - 1

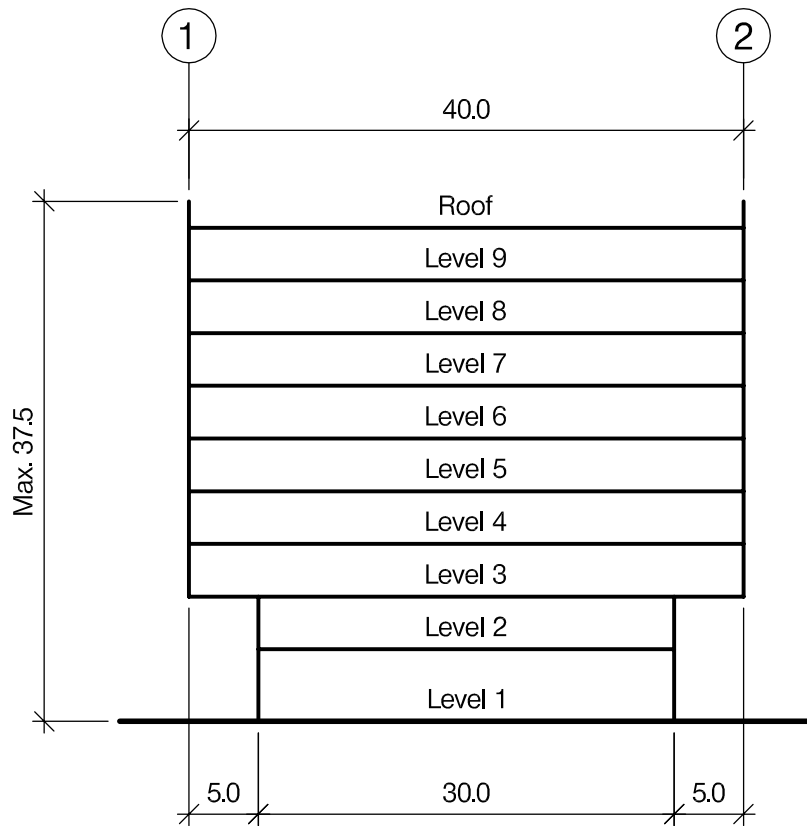

SECTION A - A

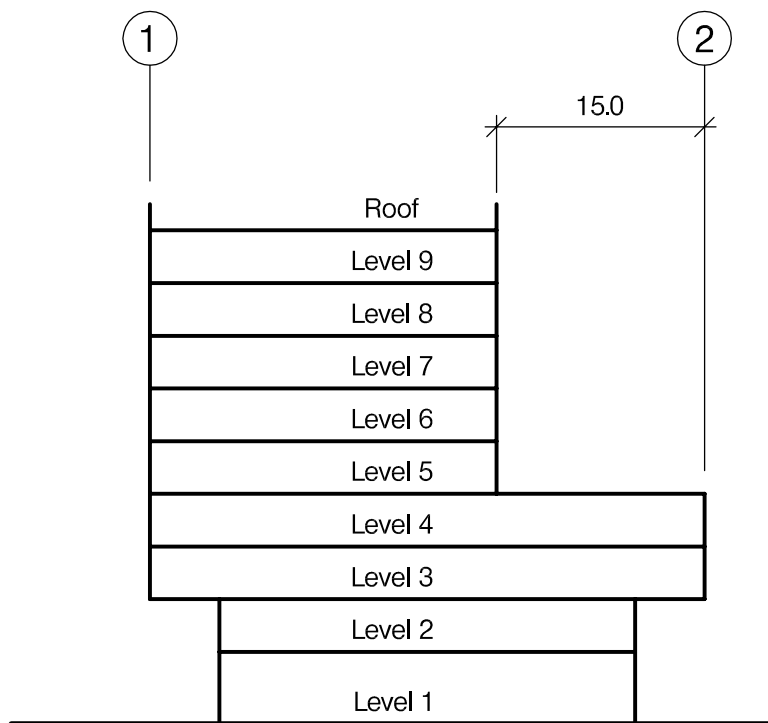

SECTION B - B

NOTE: All dimensions are in metres

FIGURE Q4 - 2

Blank Page

Question 4. A multi-storey Office

Client's requirements

1. The client requires a 9-storey office building in a modern office complex of a city centre. The building has overhangs to both front and rear elevations and a setback in the middle third in the longitudinal direction above Level 5. See Figures Q4-1 and Q4-2.
2. Level 1 needs to include a column free zone as indicated. The column spacing in the rest of Level 1 and upper floors shall not be less than 8.0m.
3. The clear floor-to-ceiling heights shall be 2.70m at Level 1 and 2.55m elsewhere. The total height of the building including a 2.5m high roof screen wall shall not exceed 37.50m. The roof is flat and accommodates plant except in the middle third. A mechanical services zone of at least 0.45m deep shall be allowed for at each level. However, this could be ignored if service ducts of 350mm can be run through the floor structure.
4. Externally the building is to be clad with an anodised aluminium cladding system with 50% glazing uniformly distributed at all elevations.
5. A minimum fire resistance period of 2 hours is required for structural elements.

Imposed loading

- | | |
|------------------|--|
| 6. Offices | 2.0 kN/m ² + 1.5 kN/m ² for partitions |
| Ground floor | 5.0 kN/m ² |
| Roof plant | 4.0 kN/m ² |
| Roof Generally | 0.6 kN/m ² |
| Corridors/stairs | 4.0 kN/m ² |

Site conditions

7. The site is flat. The basic wind speed is 60m/s based on a 3-second gust; the equivalent mean hourly wind speed is 30m/s.

Ground Conditions

8. Ground Conditions:

0.0m – 1.5m	Made Ground
1.5m – 5.0m	Medium dense sand (N=20)
Below 5.0m	Very dense sand and gravel (N=50)

Ground water was encountered at 3.0m below ground level.

Omit from consideration

9. Detailed design of staircase/lift, and façade cladding.

SECTION 1

(50 marks)

- a. Prepare a design appraisal with appropriate sketches indicating two distinct and viable solutions for the proposed structure. Indicate clearly the functional framing, load transfer and stability aspects of each scheme. Identify the solution you recommend, giving reasons for your choice. (40 marks)
- b. After completion of the scheme design for the structure, the client inquires whether a single storey basement can be added for car parking. Write a letter to the client, advising on the structural implications of this change, with a description of ways of accommodating it. (10 marks)

SECTION 2

(50 marks)

For the solution recommended in Section 1(a):

- c. Prepare sufficient design calculations to establish the form and size of all the principal structural elements including the foundations. (20 marks)
- d. Prepare general arrangement plans, sections and elevations to show the dimensions, layout and disposition of the structural elements and critical details for estimating purposes. (20 marks)
- e. Prepare a detailed method statement for the safe construction of the building and an outline construction programme. (10 marks)

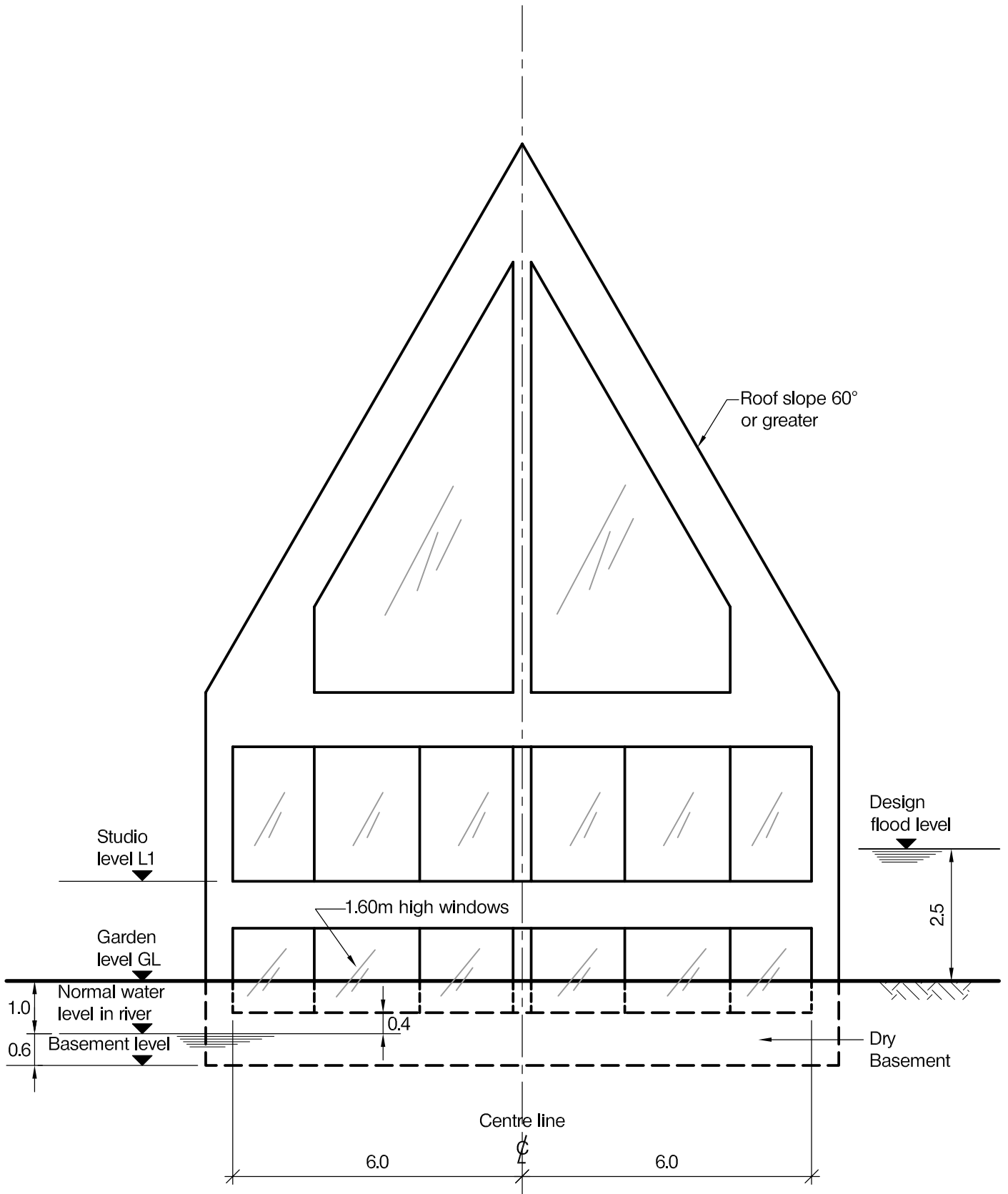

NOTE: All dimensions are in metres

FIGURE Q5

Question 5. Floating Studio

Client's requirements

1. An artist's studio with a dry basement, sited on an island in a river. The building is to sit in a wet dock, square in plan, set into the surface of a garden on the island.
2. Under normal conditions the river level is maintained by weirs at 1.0m below garden level. Under these conditions the basement floor level is to be 1.6m below garden level (see Figure Q5) and the building is to sit on supports on the floor of the dock. Water level in the dock is the same as the river level.
3. The river can flood to a level of 2.5m above the garden level. When this happens the building is required to float and to rise vertically, being prevented from sideways movement by being tethered to the dock walls.
4. The studio is to be 12.0m x 12.0m internally in plan and is to have no internal columns. A minimal internal height of 2.6m from studio floor level to eaves level is required. The roof is to be steeply pitched and the gable walls are to be glazed as much as possible to admit natural light (see Figure Q5). The basement is to have similar plan dimensions and a minimum floor-to-ceiling height of 2.6m.
5. The basement is to have windows 1.6m high on all four sides. Under normal conditions the base of the windows will be 0.4m above water level. Under no circumstances must the base of the windows be below water level.

Imposed loading

- | | |
|---|-----------------------|
| 6. Roof slopes of pitch 60 degrees or more: | |
| Maintenance load | 0.6 kN/m ² |
| Snow load | Zero |
| Services | 0.1 kN/m ² |
| Studio floor | 2.0 kN/m ² |
| Basement floor | 4.0 kN/m ² |

Horizontal forces caused by river flow are negligible even during flooding.

Site conditions

7. The garden is flat. Basic wind speed is 48m/s based on a 3-second gust; the equivalent mean hourly wind speed is 24m/s
8. Ground conditions:

Ground level - 10.0m	River gravels and sands, N=10
----------------------	-------------------------------

 Ground water level is at river level.

Omit from consideration

9. Detail design of stairs, all service and drainage connections.

SECTION 1

(50 marks)

- a. Prepare a design appraisal with appropriate sketches indicating two distinct and viable solutions for the proposed structure including the foundations. Indicate clearly the functional framing, load transfer and stability aspects of each scheme. Identify the solution you recommend, giving reasons for your choice. (40 marks)
- b. After the building has been completed and is in use, the Client enquires if it would be possible to extend one side of the studio outwards by 6.0m over its full width to gain extra space. Write a letter to the Client explaining the structural implications and how the extension might be achieved. (10 marks)

SECTION 2

(50 marks)

For the solution recommended in Section 1(a):

- c. Prepare sufficient design calculations to establish the form and size of all the principal structural elements including the foundations. (20 marks)
- d. Prepare general arrangement plans, sections and elevations to show the dimensions, layout and disposition of the structural elements and critical details for estimating purposes. (20 marks)
- e. Prepare a detailed method statement for the safe construction of the building and an outline construction programme. (10 marks)

The Institution of Structural Engineers
International HQ
47-58 Bastwick Street
London, EC1V 3PS
United Kingdom
tel: +44 (0)20 7235 4535
mail@istructe.org
www.istructe.org
Registered Charity