

Associate-Membership Examination

Friday 10th July 2015

Structural Engineering Design and Practice

09.30 – 13.00 and 13.30 – 17.00 (Discussion between individuals is not permitted during lunch period). A period of fifteen minutes is provided for reading the question paper, immediately before the commencement of the examination. Candidates are not permitted to write in answer sheets, or on drawing paper or to use a calculator during this time. Candidates must satisfy the Examiners in ONE question.

Important

The written answer to the question selected and any A3 drawings must bear the candidate's number and the question number at the bottom of the page. Only the answer sheets supplied by the Institution may be used. The candidate's name should not appear anywhere in the script.

Notes to Candidates

1. TO PASS THE EXAMINATION, CANDIDATES MUST SATISFY THE EXAMINERS IN BOTH PARTS OF THE QUESTION ATTEMPTED.
2. Examiners will only mark work written by hand during the examination.
3. A fair proportion of marks will be awarded for the demonstration of an understanding of fundamental engineering concepts, as distinct from calculation of member forces and sizes. NOTE: In the calculation part of all questions, establishing "form and size" is taken to mean compliance with all relevant design criteria, i.e. bending, shear, deflection, etc.
4. In all questions 30 marks are allocated to Section 1 and 70 marks to Section 2.

5. The Examiners are looking for sound structural designs. It should also be remembered that aesthetics, economy and function are important in any competent engineering scheme.
6. Any assumptions made and the design data and criteria adopted must be stated.
7. Good clear drawings and sketches are required; they should show all salient and structural features to suitable scales and should incorporate adequate details.
8. Candidates will not be allowed to include any previously prepared calculations, notes, sketches, diagrams, computer output or other similar material in their answer sheets or A3 drawings. Any previously prepared information submitted by candidates will be ignored by the examiners.
9. Candidates may not bring into the examination room any electronic devices capable of wireless communication, optical photography or scanning.

The following devices are not permitted: Mobile phones, Laptops, notebooks or portable computers and similar devices, iPads, tablets and similar devices, E-readers (e.g. Kindle) and similar devices, Cameras, optical scanners and similar devices.

Any candidates arriving at the examination room with such devices will be asked to switch them off and place them in a sealed bag kept by the Invigilator for the duration of the exam, which includes the lunch period.

10. This paper is set in SI Units.

Now read 'Reminder' on page 3.

Associate-Membership Examination, a reminder from your Examiners

The work you are about to start has many features in common with other examinations which you have tackled successfully but it also has some which are unusual.

As in every examination you must follow carefully the NOTES FOR CANDIDATES set out for your guidance on the front cover of this paper; allocate the available time sensibly and set out your work in a logical and clear way.

The unusual requirement of the examination is that you demonstrate the validity of the training and experience that you have acquired in recent years. The Institution must be satisfied that you are able to bring all the various skills you are expected to possess to the effective solution of structural design problems whether or not the problem is presented in terms that are within your actual experience.

Incorporated Structural Engineers must have the ability to design and a facility to communicate their design intentions. Where you are required to describe structural solutions you must show by brief, clear, logical and systematic presentation that you understand the general structural engineering principles involved.

In selecting and developing your design you should also remember the guidance given in the Institution's report, Aims of Structural Design, and in particular:

- (1) "the structure must be safe",
- (2) "a good design has certain typical features – simplicity, unity and necessity",
- (3) "the structure must fulfil its intended function".

If you have difficulty in deciding the correct interpretation of a question, pay particular attention to point 6. notes to candidates, on the front cover. The examiners will take into account your interpretation – and the design you base on this – if this is clearly stated at the beginning of your answer.

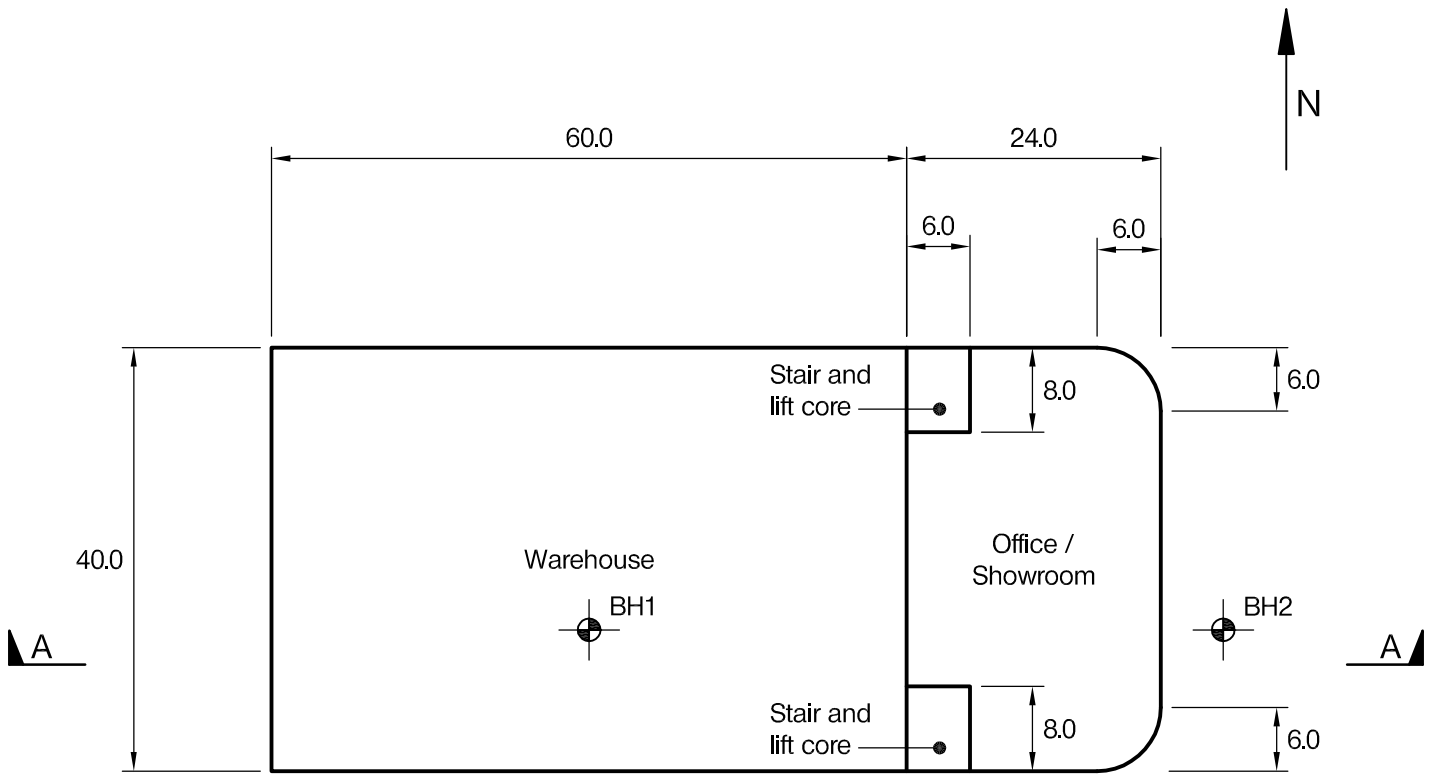

PLAN

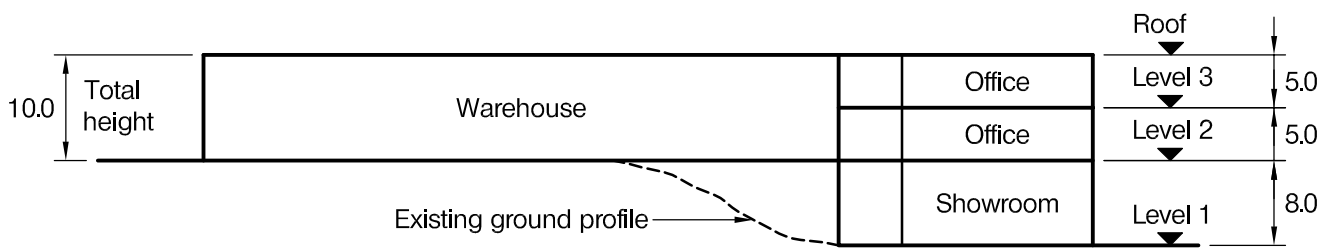

SECTION A - A

NOTE: All dimensions are in metres

FIGURE Q1

Question 1. Warehouse, office and showroom development

Client's requirements

1. A new warehouse, office and showroom development. See Figure Q1.
2. No columns are permitted within the warehouse. The roof is to be of clear span construction.
3. Only 3 columns in a single row are permitted within the office and showroom area.
4. All external columns are to be at not less than 6.0m centres.
5. Two delivery doors 6.0m high by 10.0m wide are required in the east end of the warehouse.
6. The external cladding to the warehouse is to be of insulated composite steel cladding with a single skin of 140mm concrete blockwork to a height of 3.0m above ground floor level to the inside face.
7. The external cladding to the offices is to be of glazed curtain walling with no obstructions permitted behind the glazing.
8. The roofs to the development are to be of insulated composite steel cladding.

Imposed loading

9. Roof	0.75kN/m ²
Office and Showroom	5.00kN/m ²
Warehouse	15.00kN/m ²

Imposed loading includes allowances for finishes, services and partitions.

Site conditions

10. The site located on the outskirts of a large city.
11. Basic wind speed is 40m/s based on a 3 second gust; the equivalent mean hourly wind speed is 20m/s.
12. Ground conditions:

Borehole 2	
Ground - 2.0m	Top soil and fill
2.0m - 4.5m	Sand and gravel N = 15
Below 4.5m	Very stiff clay C = 250kN/m ²
Borehole 1	
Ground - 0.5m	Top soil and fill
0.5m - 3.0m	Sand and gravel N = 15
Below 3.0m	Very stiff clay C = 250kN/m ²

Ground conditions can be assumed to vary linearly between boreholes.

Ground water was encountered at 2.5m below ground level in Borehole 2.

Omit from consideration

13. Detail design of stair and lift shaft core.

SECTION 1

(30 marks)

- a. Prepare a design appraisal with appropriate sketches indicating a viable structural solution for the proposed scheme. Indicate clearly the functional framing, load transfer and stability aspects of the scheme. Justify the reasons for the solution. (20 marks)
- b. On completion of the design the client asks if it is feasible to add two additional floors of residential accommodation above the offices. Explain the implications this will have on the design. (10 marks)

SECTION 2

(70 marks)

For the solution recommended in Section 1(a):

- c. Prepare sufficient design calculations to establish the form and size of the principal structural elements including the foundations. (30 marks)
- d. Prepare general arrangement plans, sections and elevations to show the dimensions, layout and disposition of the structural elements for estimating purposes. Prepare clearly annotated sketches to illustrate details of:
 - (i) Perimeter column to the showroom at Level 1.
 - (ii) Floor / retaining wall junction between the warehouse and the office at Level 2. (30 marks)
- e. Prepare a detailed method statement for the safe construction of the building. (10 marks)

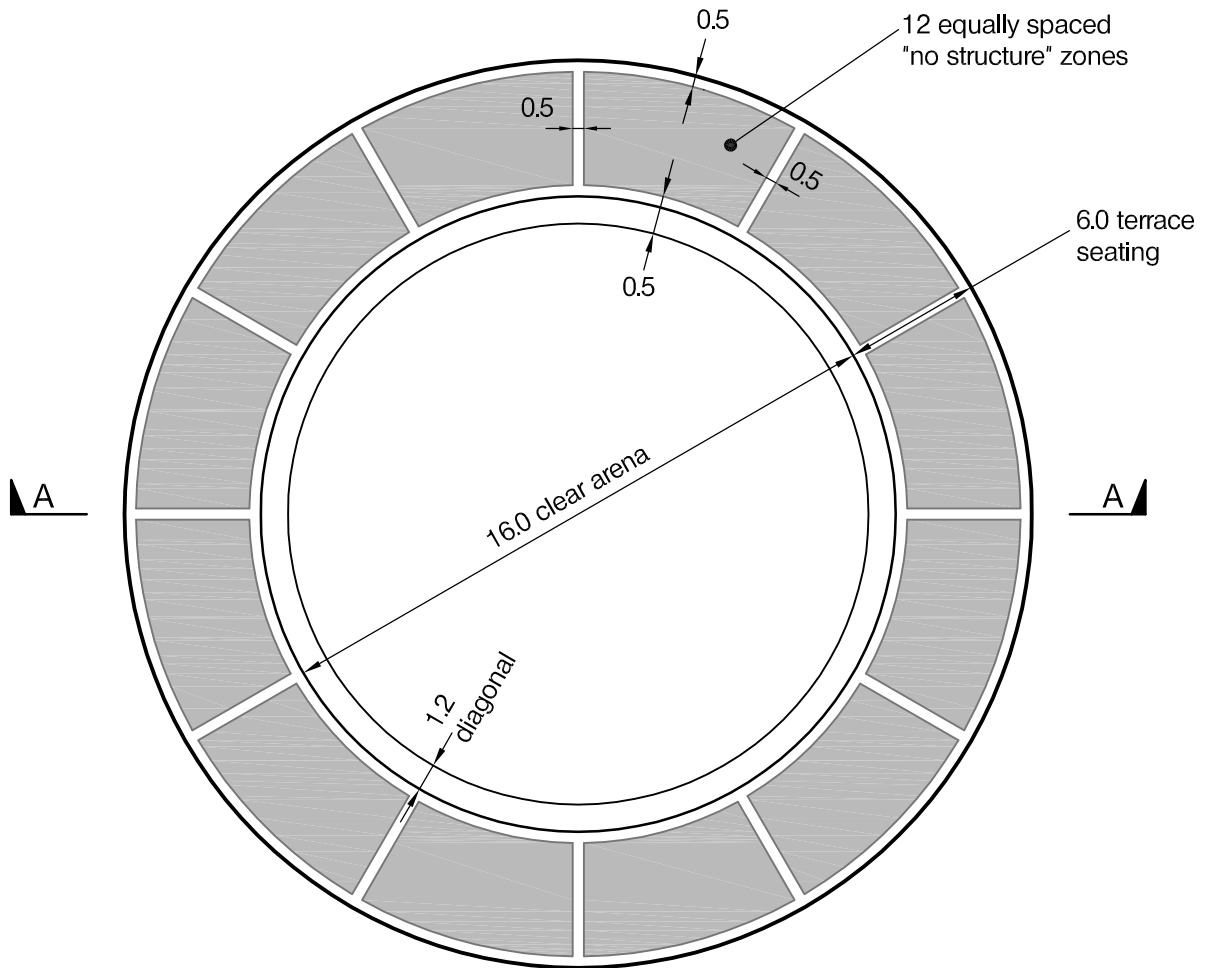
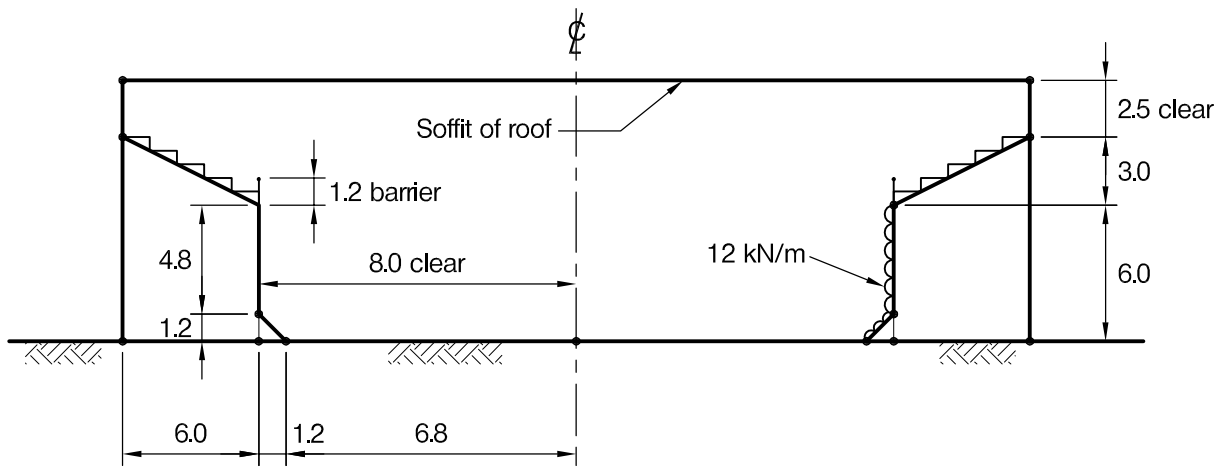

NOTE: All dimensions are in metres

FIGURE Q2

Question 2. Motorcycle stunt riding arena

Client's requirements

1. A permanent structure is required to provide an arena with a terraced viewing area for motorcycle stunt riding around the inside of a vertical circular wall, a 'wall of death'. Up to three motorcycles will be ridden around the inside surface of the wall, held in position by a combination of vertical friction and centrifugal force. See Figure Q2.
2. The structure is to comprise a 6m high inner vertical cylindrical wall having a clear internal diameter of 16m with a 1.2m diagonal at its base. This is to be surrounded by a 6m wide ring structure supporting terraced seating at the top of the wall. The arena and terraced seating is to be covered by a clear span roof with a minimum clear height of 2.5m above the terrace.
3. The structure supporting the arena wall, terraced seating and roof may not be placed in twelve zones which are reserved for access to the arena, stairs to the terraced seating and outward facing retail outlets. These 'no structure' zones are shown shaded in Figure Q2.
4. The roof may only be supported at its perimeter.
5. The client asks that the building look functional and would not object to seeing structure expressed externally.
6. The external perimeter of the structure is to be clad in a composite cladding and glazing system and the roof is to be clad with composite profile sheeting, both of which require support at a spacing of 3.0m.
7. The internal surface of the arena cylinder which forms the motorcycle track must be truly circular and may either be of concrete or of vertical timber boards supported at a spacing of 1.2m.

Imposed loading

- | | | |
|----|-------------------------|---|
| 8. | Roof | 1.00kN/m ² |
| | Floor and terrace | 10.00kN/m ² |
| | Arena cylindrical walls | The design loading from the motorcycles may be considered as a uniformly distributed vertical line load of 12.00kN/m run, acting outwards normal to the arena wall surface in any one radial position. See Figure Q2. |

Imposed loading includes allowance for finishes, services and dynamic effects.

Site conditions

9. The site is in a small park in a built up area.
10. Basic wind speed is 38m/s based on a 3 second gust; the equivalent mean hourly wind speed is 19m/s.
11. Ground conditions:

Ground level – 1.0m	Vegetation and topsoil.
1.5m – 30m	Clay with cohesion varying linearly from $C = 60\text{kN/m}^2$ at a depth of 1.0m to $C = 180\text{kN/m}^2$ at a depth of 31m.

The highest recorded ground water level is 10.0m below ground level.

Omit from consideration

12. Design of the roof cladding and external wall cladding, design of any timber track surface boards which may be used, design of the stairs and design of the entrance doors to the motorcycle arena.

SECTION 1

(30 marks)

- a. Prepare a design appraisal with appropriate sketches indicating a viable structural solution for the proposed scheme. Indicate clearly the functional framing, load transfer and stability aspects of the scheme. Justify the reasons for the solution. (20 marks)
- b. After opening there are complaints of noise from nearby residents and the client asks whether it would be feasible to add heavy acoustic panels weighing an additional 2.00kN/m² to the roof. Write a note outlining the implications of this and describing a possible way of strengthening the structure to safely carry the additional dead load, using sketches as necessary to illustrate your response. (10 marks)

SECTION 2

(70 marks)

For the solution recommended in Section 1(a):

- c. Prepare sufficient design calculations to establish the form and size of the principal structural elements including the foundations. (30 marks)
- d. Prepare general arrangement plans, sections and elevations to show the dimensions, layout and disposition of the structural elements for estimating purposes. Prepare clearly annotated sketches to illustrate details of:
 - (i) The connection between a typical external perimeter column and roof including cladding and cladding support arrangement.
 - (ii) A cross section through the lowest 2 metres of the cylindrical track wall and base including reinforcement detailing and fixing of any track surface elements which may be used. (30 marks)
- e. Prepare a method statement for construction and erection of the roof structure. (10 marks)

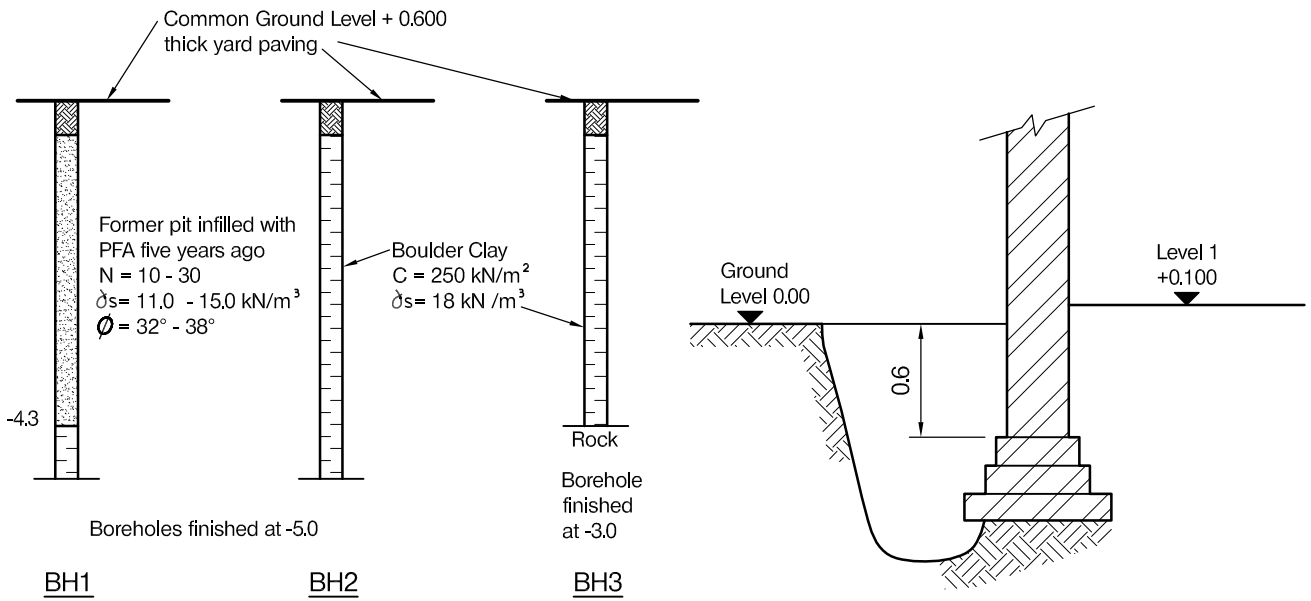
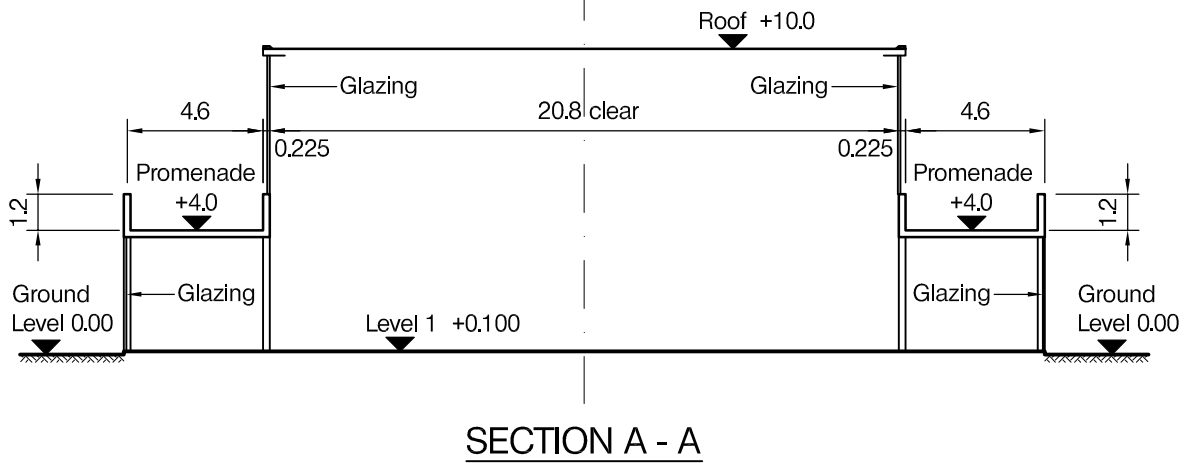
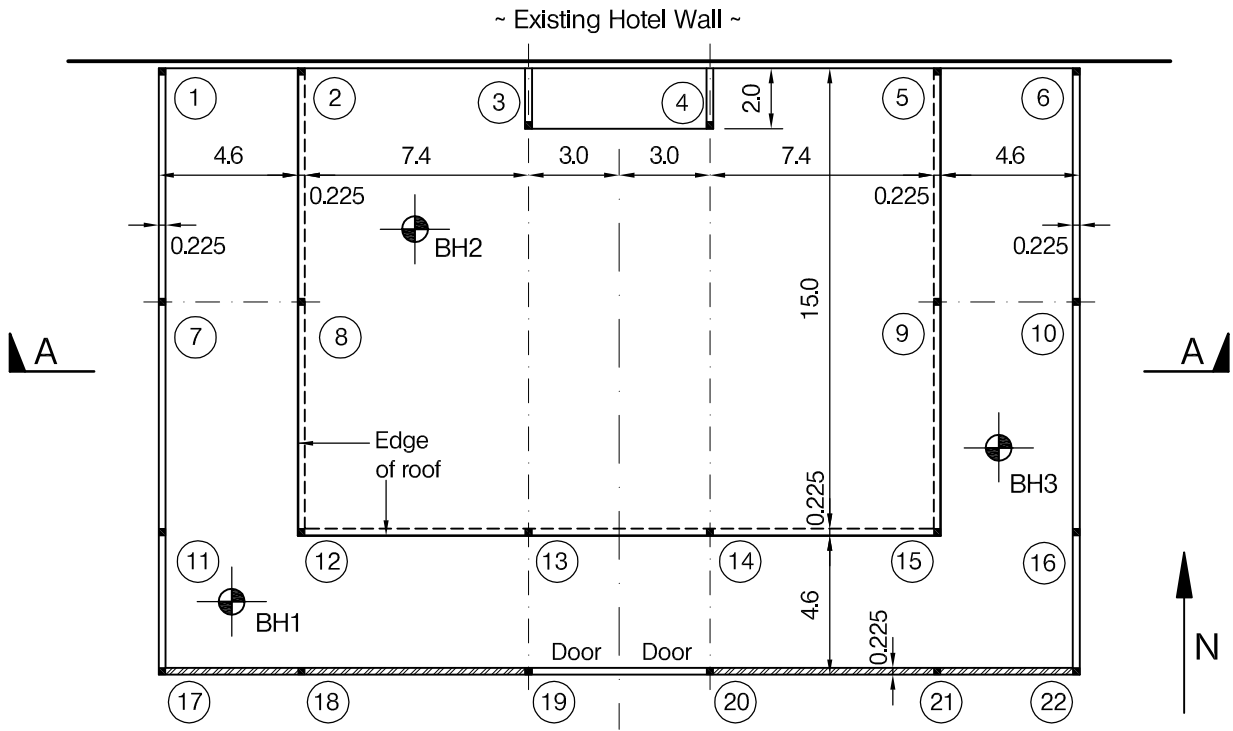

No groundwater was found in any of the boreholes

NOTE: All dimensions are in metres

FIGURE Q3

Question 3. Hotel ballroom

Client's requirements

1. A ballroom extension to an existing hotel. See Figure Q3. The ballroom has an elevated promenade on three sides. The ballroom can be accessed on Level 1 from the hotel or from doors in the south elevation.
2. Columns are permitted at the twenty-two positions shown on the plan. The positions of two columns only may be repositioned by the designer.
3. The east and west sides of the hall are glazed. The northern side of the hall (adjacent to the existing hotel) is required to have a fire resistance of 2 hours. The glazing at the sides of the upper portion of the ballroom, above promenade level, is to be continued across the southern elevation.
4. The maximum structural depth of the ballroom roof is to be 1.3m. The ballroom roof is to be flat with drainage falls. The promenade roof is to be finished with quarry tiles.
5. Brick infill is proposed for the southern wall of the ballroom below promenade level.
6. The existing hotel wall is 13.5m high and is of old brick construction. It can support no further load.

Imposed loading

- | | |
|-----------|-----------------------|
| 7. Roof | 1.50kN/m ² |
| Promenade | 5.00kN/m ² |
| Floor | 5.00kN/m ² |
- Imposed loading includes allowances for finishes, services and partitions.

Site conditions

8. The site is at sea level and located on the outskirts of a new town 9 km from the coast.
9. Basic wind speed is 44m/s based on a 3 second gust; the equivalent mean hourly wind speed is 22m/s.
10. Ground conditions:
Three boreholes have been sunk at positions shown in Figure Q3. A trial pit was dug adjacent to the existing hotel wall, see Figure Q3.

Omit from consideration

11. Detailed design of glazing and roof covering.

SECTION 1

(30 marks)

- a. Prepare a design appraisal with appropriate sketches indicating a viable structural solution for the proposed scheme. Indicate clearly the functional framing, load transfer and stability aspects of the scheme. Justify the reasons for the solution. (20 marks)
- b. After completion of the design and before construction, the client wishes to hang theatre lighting and possibly scenery from the hall roof, increasing the general imposed loading on the roof to 2.0 kN/m². Explain how this could be achieved, using sketches as necessary to illustrate your solution. (10 marks)

SECTION 2

(70 marks)

For the solution recommended in Section 1(a):

- c. Prepare sufficient design calculations to establish the form and size of the principal structural elements including the foundations. (30 marks)
- d. Prepare general arrangement plans, sections and elevations to show the dimensions, layout and disposition of the structural elements for estimating purposes. Prepare clearly annotated sketches to illustrate details of:
 - (i) The ballroom roof where it abuts the existing hotel wall.
 - (ii) The promenade roof, upstand and connection to an internal column. (30 marks)
- e. Prepare a detailed method statement for the safe construction of the building. (10 marks)

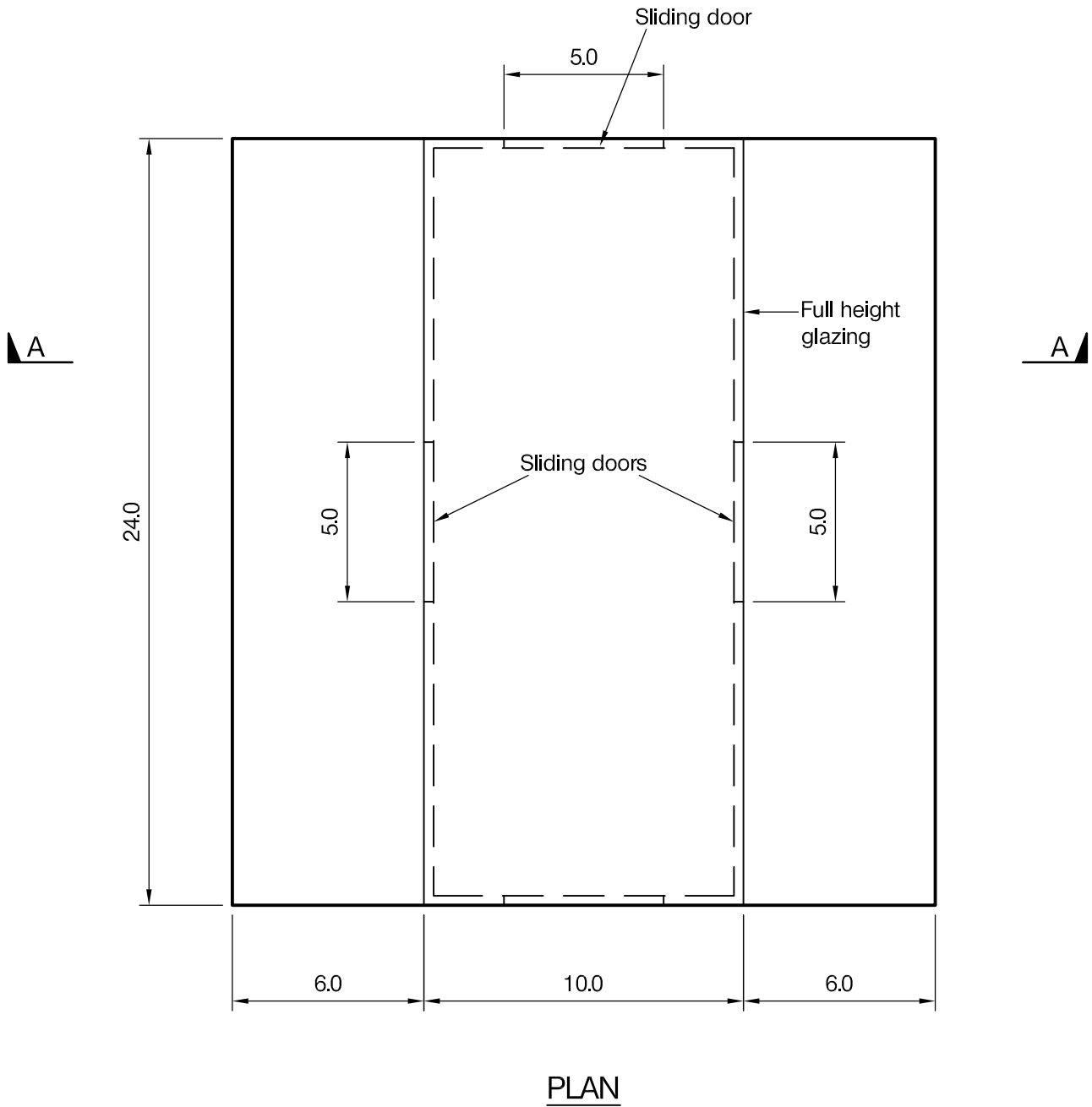

PLAN

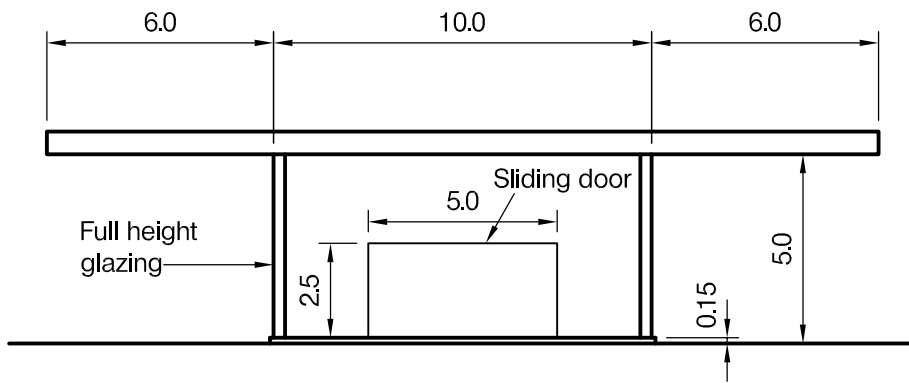

SECTION A - A

NOTE: All dimensions are in metres

FIGURE Q4

Question 4. Coach reception building

Client's requirements

1. An open plan fully vertically glazed coach reception building with cantilever roof projections. See Figure Q4.
2. The interior of the building is to be free of obstructions.
3. The building is to be of attractive appearance, therefore any visible structural elements need to be carefully designed.
4. Due to the presence of the glazing lateral deflections of the building structure are required to be limited to height/500 and vertical deflections of the roof structure to span/360.

Imposed loading

5. Roof 0.75kN/m²

Site conditions

6. The site level.
7. Basic wind speed is 44m/s based on a 3 second gust; the equivalent mean hourly wind speed is 22m/s.
8. Ground conditions:

Ground - 6.0m	Loose fill material
Below 6.0m	Mudstone with an allowable bearing pressure of 200kN/m ² .

Site investigation noted significant water ingress at 1.0m below ground level.

Omit from consideration

9. Detailed design of glazing and roof covering.

SECTION 1

(30 marks)

- a. Prepare a design appraisal with appropriate sketches indicating a viable structural solution for the proposed scheme. Indicate clearly the functional framing, load transfer and stability aspects of the scheme. Justify the reasons for the solution. (20 marks)
- b. Upon completion of the design the client asks whether the glazing could just extend to 4m height with a section of cladding above. Describe the implications this will have on the original design. (10 marks)

SECTION 2

(70 marks)

For the solution recommended in Section 1(a):

- c. Prepare sufficient design calculations to establish the form and size of the principal structural elements including the foundations. (30 marks)
- d. Prepare general arrangement plans, sections and elevations to show the dimensions, layout and disposition of the structural elements for estimating purposes. Prepare clearly annotated sketches to illustrate details of:
 - (i) The junction between the supporting members and the foundations.
 - (ii) The junction between the cantilever roof projections and the main structure. (30 marks)
- e. Prepare a detailed method statement for the safe construction of the building. (10 marks)

The Institution of Structural Engineers
International HQ
47-58 Bastwick Street
London, EC1V 3PS
United Kingdom
tel: +44 (0)20 7235 4535
mail@istructe.org
www.istructe.org
Registered Charity