

Associate-Membership Examination

Friday 25 April 2014

Structural Engineering Design and Practice

09.30 – 13.00 and 13.30 – 17.00 (Discussion between individuals is not permitted during lunch period). A period of fifteen minutes is provided for reading the question paper, immediately before the commencement of the examination. Candidates are not permitted to write in answer sheets, or on drawing paper or to use a calculator during this time. Candidates must satisfy the Examiners in ONE question.

Important

The written answer to the question selected and any A3 drawings must bear the candidate's number and the question number at the bottom of the page. Only the answer sheets supplied by the Institution may be used. The candidate's name should not appear anywhere in the script.

Notes to Candidates

1. TO PASS THE EXAMINATION, CANDIDATES MUST SATISFY THE EXAMINERS IN BOTH PARTS OF THE QUESTION ATTEMPTED.
2. Examiners will only mark work written by hand during the examination.
3. A fair proportion of marks will be awarded for the demonstration of an understanding of fundamental engineering concepts, as distinct from calculation of member forces and sizes. NOTE: In the calculation part of all questions, establishing "form and size" is taken to mean compliance with all relevant design criteria, i.e. bending, shear, deflection, etc.
4. In all questions 30 marks are allocated to Section 1 and 70 marks to Section 2.
5. The Examiners are looking for sound structural designs. It should also be remembered that aesthetics, economy and function are important in any competent engineering scheme.
6. Any assumptions made and the design data and criteria adopted must be stated.
7. Portable computers or programmable calculators may be used but sufficient calculations must be submitted to substantiate the design, and these should be set out as in practice.
8. Good clear drawings and sketches are required; they should show all salient and structural features to suitable scales and should incorporate adequate details.
9. Candidates will not be allowed to include any previously prepared calculations, notes, sketches, diagrams, computer output or other similar material in their answer sheets or A3 drawings. Any previously prepared information submitted by candidates will be ignored by the examiners.
10. Strictly no external electronic contact is allowed between a candidate and anyone outside the examination venue. Mobile phones must be switched off throughout the duration of the examination.
11. This paper is set in SI Units.

Now read 'Reminder' on page 3.

Associate-Membership Examination, a reminder from your Examiners

The work you are about to start has many features in common with other examinations which you have tackled successfully but it also has some which are unusual.

As in every examination you must follow carefully the NOTES FOR CANDIDATES set out for your guidance on the front cover of this paper; allocate the available time sensibly and set out your work in a logical and clear way.

The unusual requirement of the examination is that you demonstrate the validity of the training and experience that you have acquired in recent years. The Institution must be satisfied that you are able to bring all the various skills you are expected to possess to the effective solution of structural design problems – whether or not the problem is presented in terms that are within your actual experience.

Incorporated Structural Engineers must have the ability to design and a facility to communicate their design intentions. Where you are required to describe structural solutions you must show by brief, clear, logical and systematic presentation that you understand the general structural engineering principles involved.

In selecting and developing your design you should also remember the guidance given in the Institution's report, Aims of Structural Design, and in particular:

- (1) "the structure must be safe",
- (2) "a good design has certain typical features – simplicity, unity and necessity",
- (3) "the structure must fulfil its intended function".

If you have difficulty in deciding the correct interpretation of a question, pay particular attention to point 6. notes to candidates, on the front cover. The examiners will take into account your interpretation – and the design you base on this – if this is clearly stated at the beginning of your answer.

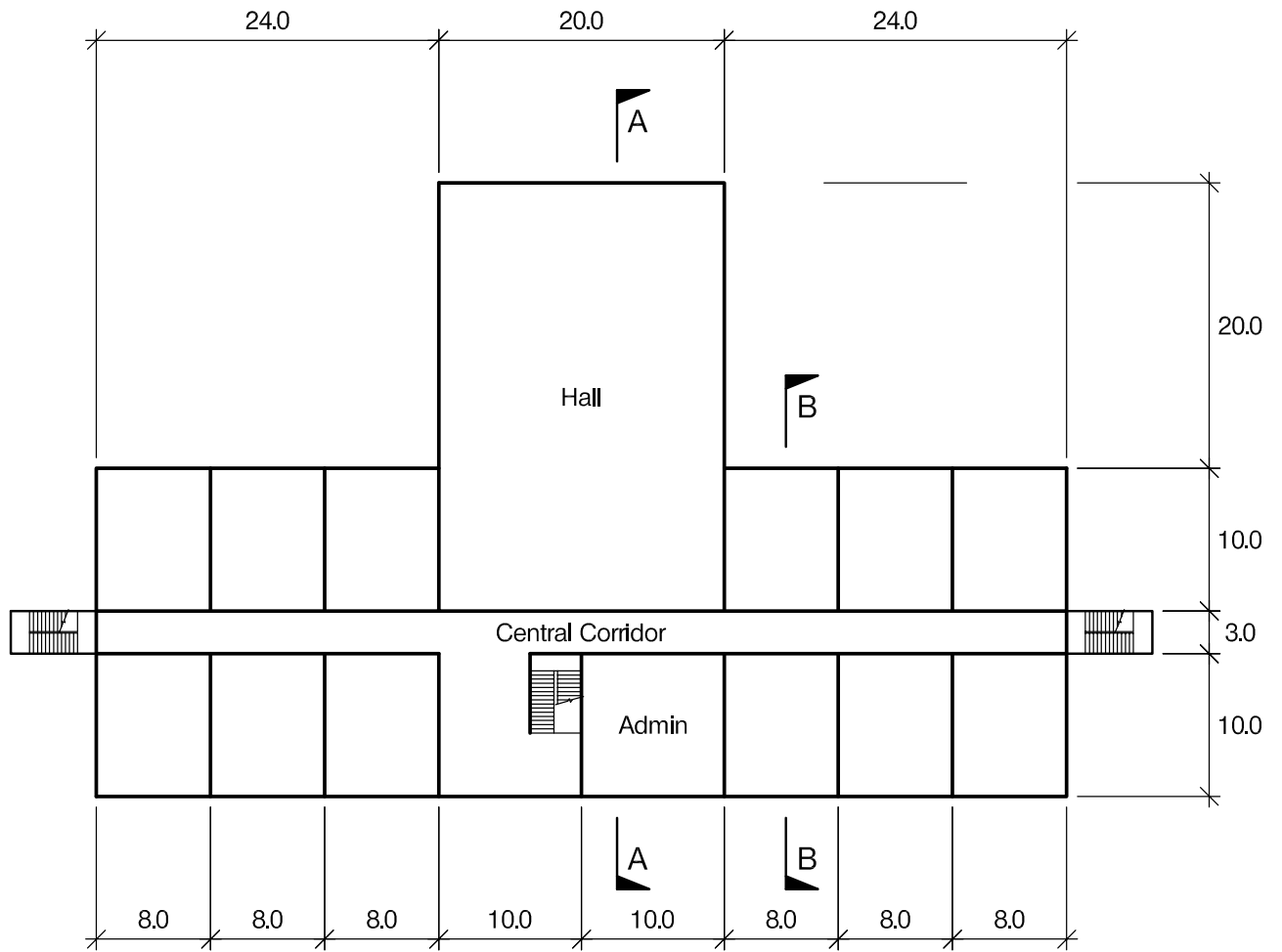

PLAN

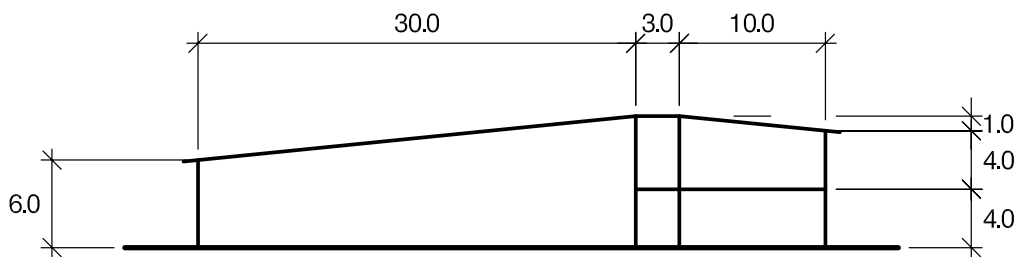

SECTION A - A

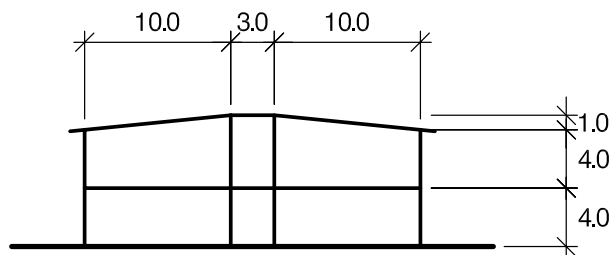

SECTION B - B

NOTE: All dimensions are in metres

FIGURE Q1

Question 1. School building

Client's requirements

1. A two storey school building is required for a new town. See Figure Q1.
2. The school building is to provide 24 classrooms located on two levels, equally divided either side of a hall and administration facilities. The classrooms are to be accessed from a central corridor at each level.
3. Columns are only permitted around the perimeter of the building and on the wall lines of the central corridor.
4. The internal clear floor height to all areas, except the hall, is to be 2.8m with a 200mm clear service zone under the structure.
5. An external enclosed staircase is required at each end of the central corridor.
6. The building is to be clad in a flat composite cladding system and the roof is clad with composite profile sheeting.

Imposed loading

- | | |
|---------|-----------------------|
| 7. Roof | 0.75kN/m ² |
| Floors | 3.00kN/m ² |
- Imposed loading includes allowances for finishes, services and partitions.

Site conditions

8. The site is level and located on the outskirts of the new town.
9. Basic wind speed is 40.0m/s based on a 3-second gust; the equivalent mean hourly wind speed is 20.0m/s.
10. Ground conditions:

Ground – 1.0m	Top soil and fill
1.0m – 2.0m	Soft clay, C = 10kN/m ²
2.0m – 6.0m	Stiff clay, C = 100kN/m ²

No ground water was encountered.

Omit from consideration

11. Detailed design of the external staircases as they do not contribute to the overall stability.

SECTION 1

(30 marks)

- a. Prepare a design appraisal with appropriate sketches indicating a viable structural solution for the proposed scheme. Indicate clearly the functional framing, load transfer and stability aspects of the scheme. Justify the reasons for the solution. (20 marks)
- b. After completion of the design and before construction, the client asks whether theatre lighting and possible scenery could be hung from the hall roof increasing the general imposed loading on the roof to 2.0kN/m². Explain how this could be achieved using sketches as necessary to illustrate your solution. (10 marks)

SECTION 2

(70 marks)

For the solution recommended in Section 1(a):

- c. Prepare sufficient design calculations to establish the form and size of the principal structural elements including the foundations. (30 marks)
- d. Prepare general arrangement plans, sections and elevations to show the dimensions, layout and disposition of the structural elements for estimating purposes. Prepare clearly annotated sketches to illustrate details of:
 - (i) The roof at eaves level.
 - (ii) A perimeter column at ground floor level. (30 marks)
- e. Prepare a detailed method statement for the safe construction of the building. (10 marks)

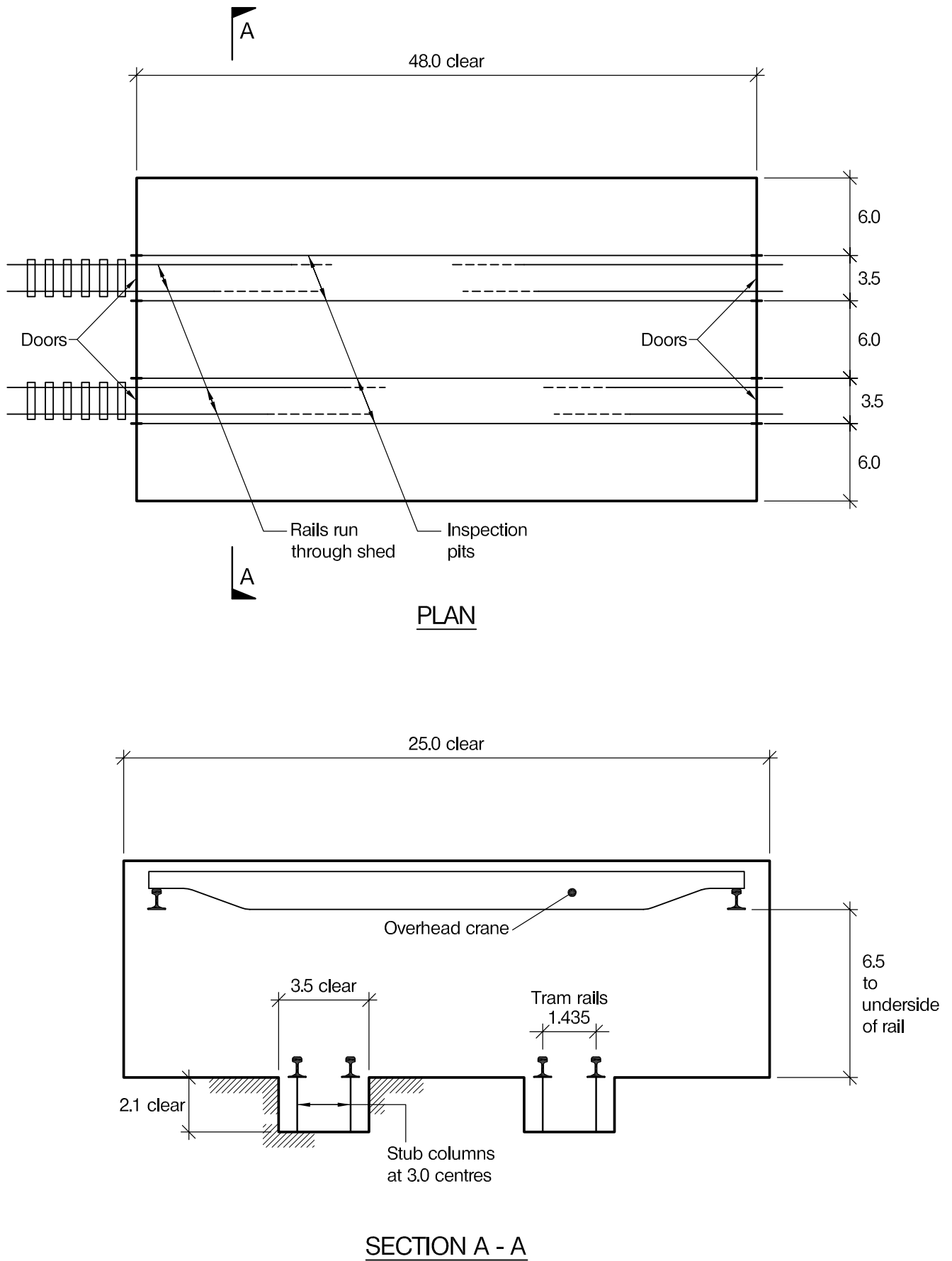

NOTE: All dimensions are in metres

FIGURE Q2

Question 2. Tram maintenance shed

Client's requirements

1. A maintenance shed is required as part of the depot for a new tram system for a large city. See Figure Q2.
2. The minimum clear plan dimensions of the shed are to be 25.0m wide by 48.0m long and there are to be no internal columns.
3. An overhead crane spanning 24.0m from side to side and capable of travelling the full length of the shed is required. The crane is to run on rails supported by crane beams fixed to the side walls of the shed. To provide sufficient working headroom the bottom of the crane rails is to be 6.5m above the floor.
4. There are to be two maintenance pits running the full length of the building with clear internal dimensions 3.5m wide by 2.1m deep. The tram rails are to be supported on longitudinal beams spanning between stub columns spaced at 3.0m centres along the pits.
5. The client asks that the building look as elegant as possible, consistent with its required function, and that as much of the roof as possible be glazed to allow for natural lighting.
6. The site has been used previously and some of the ground is believed to be contaminated.

Imposed loading

- | | |
|------------|--|
| 7. Roof | 1.0kN/m ² |
| Crane rail | 100kN point load considered anywhere along each crane rail |
| Floor | 12.5kN/m ² together with a point load of 25.0kN anywhere on the floor surface |
| Tram rail | 10.0kN/m per rail together with a point load of 25.0kN per rail anywhere along the length of each rail |

The roof and floor loadings include allowances for finishes, partitions and services.

Site conditions

8. The site is level and open and at the edge of the city. There is a river about 300m from the site.
9. Basic wind speed is 40.0m/s based on a 3-second gust; the equivalent mean hourly wind speed is 20.0m/s.
10. Ground conditions:

Ground – 1.0m	Contaminated topsoil and fill
1.0m – 30.0m	Dense sand, N = 40

 The highest recorded ground water level is 1.5 m below ground level.

Omit from consideration

11. Design of the overhead crane and crane rails and design of tram entrance and exit doors.

SECTION 1

(30 marks)

- a. Prepare a design appraisal with appropriate sketches indicating a viable structural solution for the proposed scheme. Indicate clearly the functional framing, load transfer and stability aspects of the scheme. Justify the reasons for the solution. (20 marks)
- b. During the tender process the client is advised that he can make significant savings if he buys two overhead cranes spanning 11.5m rather than one spanning 24.0m. He asks what changes this would make to the structure. Illustrate your reply with sketches as necessary. (10 marks)

SECTION 2

(70 marks)

For the solution recommended in Section 1(a):

- c. Prepare sufficient design calculations to establish the form and size of the principal structural elements including the foundations. (30 marks)
- d. Prepare general arrangement plans, sections and elevations to show the dimensions, layout and disposition of the structural elements for estimating purposes. Prepare clearly annotated sketches to illustrate details of:
 - (i) The connection between the crane support beams and edge columns.
 - (ii) A cross section through the inspection pits including reinforcement detailing. (30 marks)
- e. Prepare a method statement for construction of the foundations, inspection pits and ground floor slab. (10 marks)

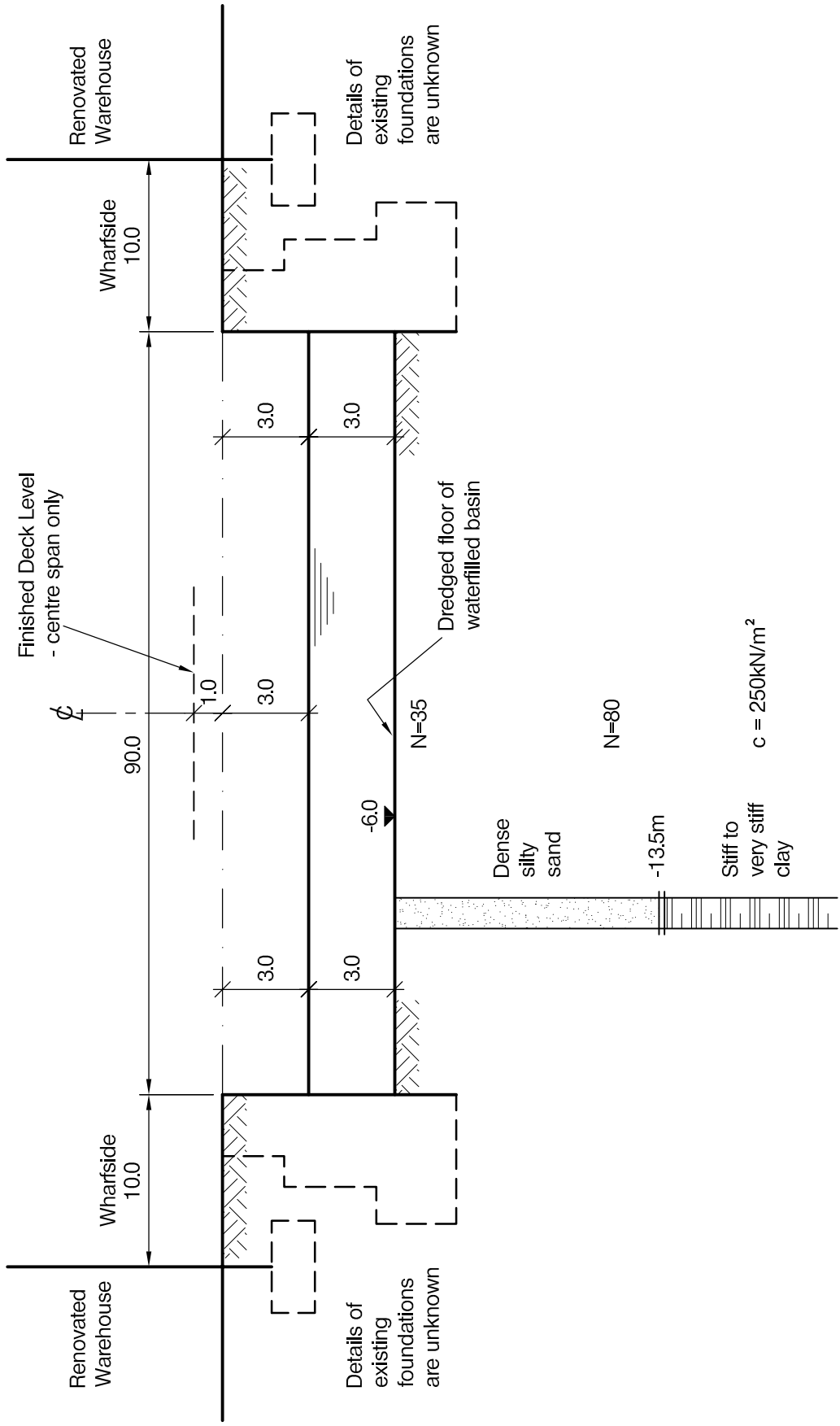

NOTE: All dimensions are in metres

FIGURE Q3

Question 3. Ornamental footbridge

Client's requirements

1. A three span ornamental public footbridge is required as part of the re-development of a coal dock in the port area of a large city. See Figure Q3.
2. Former coal wharves form the sides of a 90.0m wide area of water which is to be crossed by the footbridge.
3. The footbridge is to have a clear width between parapets of 7.0m. It is to be accessible by wheelchairs and by large numbers of people when boating events are held on the water.
4. The bridge may be constructed in any material or combination of materials. However a low maintenance bridge with a design life of 60 years is required.
5. Street lights, planters and occasional seating are required on the footbridge.

Imposed loading

- | | |
|--------------------|----------------------|
| 6. Finishes | 5.0kN/m ² |
| Pedestrian loading | 5.0kN/m ² |

Site conditions

7. The site is level and is located within a busy city port facility.
8. Basic wind speed is 40.0m/s based on a 3-second gust; the equivalent mean hourly wind speed is 20.0m/s.
9. Ground conditions:

Ground – 6.0m	Made ground and existing foundations
6.0m – 13.5m	Dense silty sand, N varies from 35 to 80
Below 13.5m	Stiff to very stiff clay, C = 250kN/m ²

Omit from consideration

10. Design of street light supports, planters and seating.

SECTION 1

(30 marks)

- a. Prepare a design appraisal with appropriate sketches indicating a viable structural solution for the proposed scheme. Indicate clearly the functional framing, load transfer and stability aspects of the scheme. Justify the reasons for the solution. (20 marks)
- b. Before completion of the design, the client requests that a section of the bridge be able to open to enable small sailing boats to pass through. Explain how this will affect the design and details of the bridge. (10 marks)

SECTION 2

(70 marks)

For the solution recommended in Section 1(a):

- c. Prepare sufficient design calculations to establish the form and size of the principal structural elements including the foundations. (30 marks)
- d. Prepare general arrangement plans, sections and elevations to show the dimensions, layout and disposition of the structural elements for estimating purposes. Prepare clearly annotated sketches to illustrate details of:
 - (i) Junction between the footbridge superstructure and the wharfside substructure supports.
 - (ii) A connection between two structural elements of the footbridge superstructure. (30 marks)
- e. Prepare a detailed method statement for the safe construction of the footbridge. (10 marks)

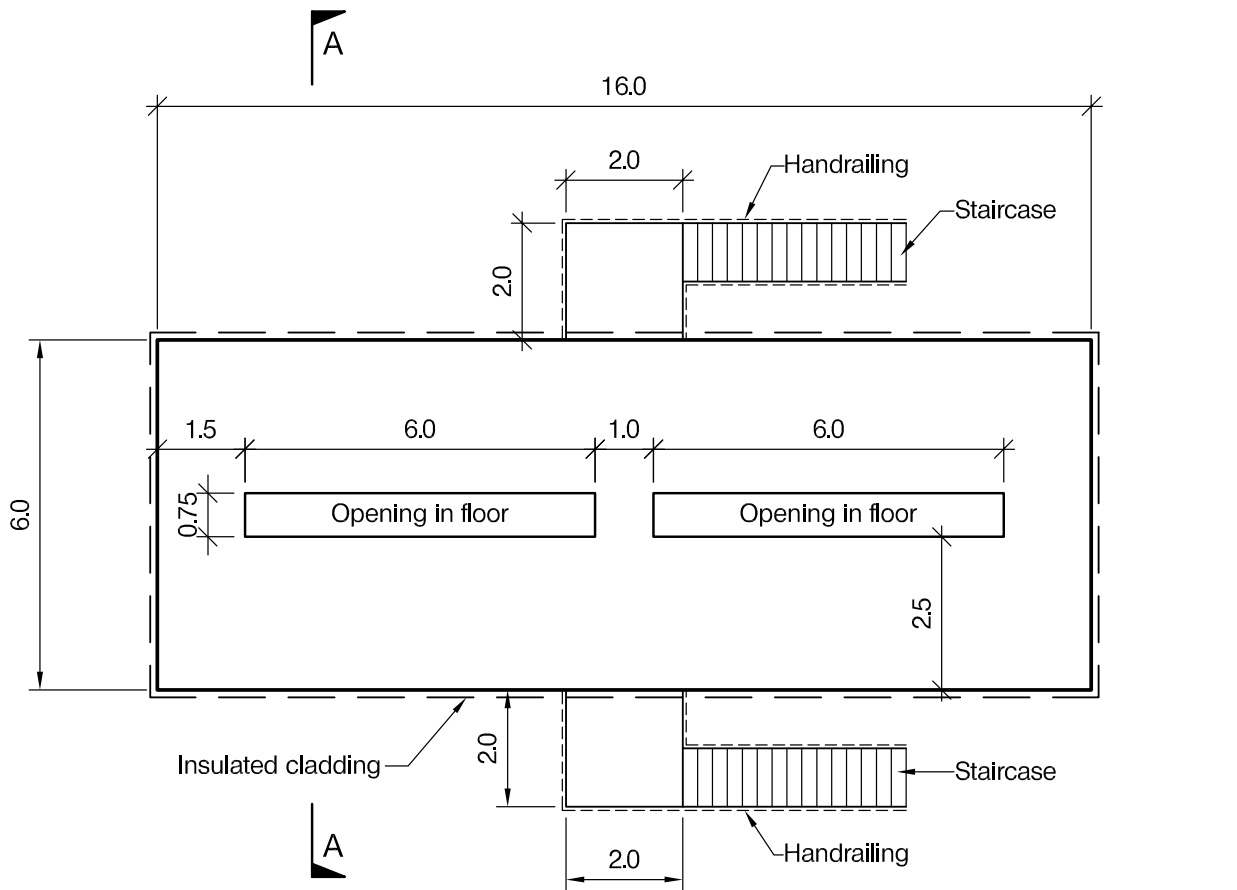

PLAN

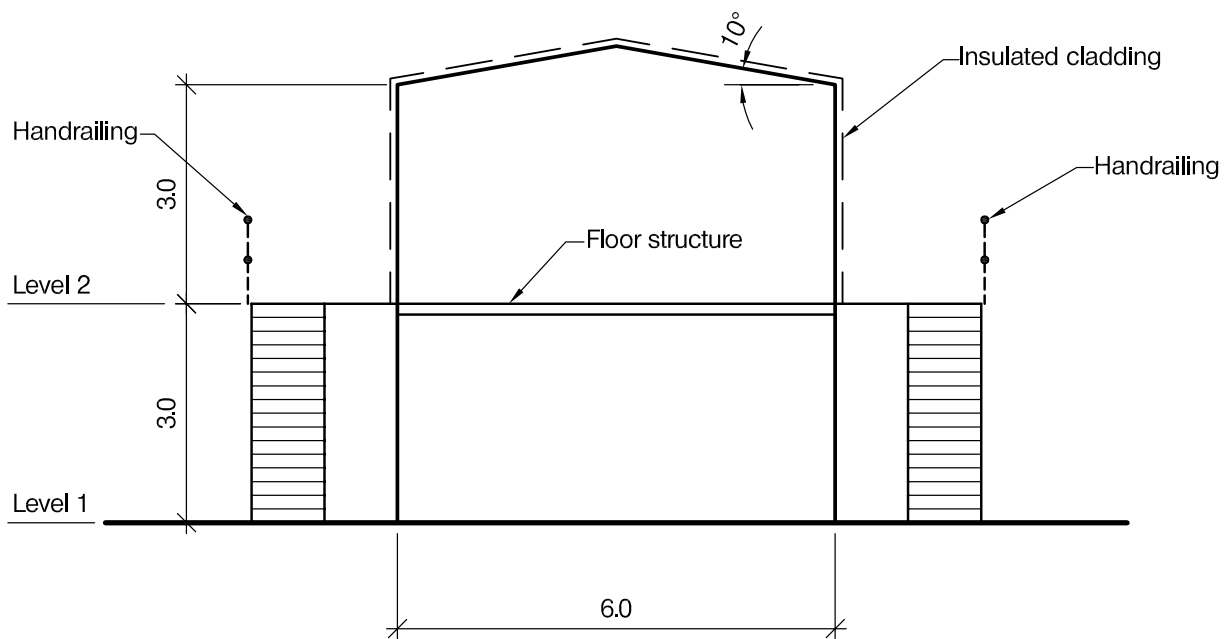

SECTION A - A

NOTE: All dimensions are in metres

FIGURE Q4

Question 4. Elevated electrical equipment structure

Client's requirements

1. An elevated weatherproof structure is required for the housing of sensitive high voltage electrical equipment. See Figure Q4.
2. The structure comprises an elevated structure at level two with an accessible area below, complete with cable openings through the floor.
3. There is to be a minimum of obstructions within the interior of the level one area and no obstructions within the interior of the level two area.
4. Two external staircases are required to provide access to the level two floor of the building.

Imposed loading

- | | |
|---------|------------------------|
| 5. Roof | 0.75kN/m ² |
| Floors | 10.00kN/m ² |
- Imposed loading includes allowances for finishes, services and partitions.

Site conditions

6. The site is level.
7. Basic wind speed is 44.0m/s based on a 3-second gust; the equivalent mean hourly wind speed is 22.0m/s.
8. Ground conditions:

Ground – 3.0m	Loose fill material
Below 3.0m	Stiff clay, allowable bearing pressure 150kN/m ²

 Site investigation noted significant water ingress at 1.5m below ground level.

Omit from consideration

9. Detailed design of cladding.

SECTION 1

(30 marks)

- a. Prepare a design appraisal with appropriate sketches indicating a viable structural solution for the proposed scheme. Indicate clearly the functional framing, load transfer and stability aspects of the scheme. Justify the reasons for the solution. (20 marks)
- b. Upon completion of the design the client asks if the height above ground level of the level two floor can be increased to 5.0m. Describe the implications this will have on the original design. (10 marks)

SECTION 2

(70 marks)

For the solution recommended in Section 1(a):

- c. Prepare sufficient design calculations to establish the form and size of the principal structural elements including the foundations. (30 marks)
- d. Prepare general arrangement plans, sections and elevations to show the dimensions, layout and disposition of the structural elements for estimating purposes. Prepare clearly annotated sketches to illustrate details of:
 - (i) The junction of the supporting members with the foundations.
 - (ii) The junction of the staircase landings and the perimeter of the level two floor structure. (30 marks)
- e. Prepare a detailed method statement for the safe construction of the structure. (10 marks)

The Institution of Structural Engineers
International HQ
11 Upper Belgrave Street
London SW1X 8BH
United Kingdom
tel: +44 (0)20 7235 4535
fax: +44 (0)20 7235 4294
mail@istructe.org
www.istructe.org
Registered Charity