

## Chartered Membership Examination

Thursday 8 April 2021

### Structural Engineering Design and Practice

09.30 – 13.00 and 13.30 – 17.00 (Discussion between individuals is not permitted during lunch period). A period of fifteen minutes is provided for reading the question paper, immediately before the commencement of the examination. Candidates are not permitted to write in answer sheets, or on drawing paper or to use a calculator during this time. Candidates must satisfy the Examiners in ONE question.

### Important

The written answer to the question selected and any A3 drawings must bear the candidate's number and the question number at the bottom of the page. Only the answer sheets supplied by the Institution may be used. The candidate's name should not appear anywhere in the script.

### Notes to Candidates

1. TO PASS THE EXAMINATION, CANDIDATES MUST SATISFY THE EXAMINERS IN BOTH PARTS OF THE QUESTION ATTEMPTED.
2. Candidates should note that Figures are produced to illustrate the question and are not necessarily drawn to scale. Figured dimensions should be followed.
3. A fair proportion of marks will be awarded for the demonstration of an understanding of fundamental engineering concepts, as distinct from calculation of member forces and sizes. NOTE: In the calculation part of all questions, establishing "form and size" is taken to mean compliance with all relevant design criteria, i.e. bending, shear, deflection, etc.
4. In all questions 50 marks are allocated to Section 1 and 50 marks to Section 2.

5. The Examiners are looking for sound structural designs. It should also be remembered that aesthetics, economy and function are important in any competent engineering scheme.
6. Any assumptions made and the design data and criteria adopted must be stated.
7. Clear drawings and sketches are required. They do not have to be to a defined scale, but should be in proportion.
8. Candidates will not be allowed to include any previously prepared calculations, notes, sketches, diagrams, computer output or other similar material in their answer sheets or A3 drawings. Any previously prepared information submitted by candidates will be ignored by the examiners.
9. Candidates may not bring into the examination room any electronic devices capable of wireless communication, optical photography or scanning.

The following devices are not permitted: mobile phones, laptops, notebooks or portable computers and similar devices, iPads, tablets and similar devices, e-readers (e.g. Kindle) and similar devices, cameras, optical scanners and similar devices.

Any candidates arriving at the examination room with such devices will be asked to switch them off and place them in a sealed bag kept by the Invigilator for the duration of the exam, which includes the lunch period.

10. This paper is set in SI Units.

**Now read 'Reminder' on page 3.**

**BLANK PAGE**

# Chartered Membership Examination, a reminder from your Examiners

The work you are about to start has many features in common with other examinations which you have tackled successfully but it also has some which are unusual.

As in every examination you must follow carefully the NOTES FOR CANDIDATES set out for your guidance on the front cover of this paper; allocate the available time sensibly and set out your work in a logical and clear way.

The unusual requirement of the examination is that you demonstrate the validity of the training and experience that you have acquired in recent years.

The Institution must be satisfied that you are able to bring all the various skills you are expected to possess to the effective solution of structural design problems whether or not the problem is presented in terms that are within your actual experience.

Chartered Structural Engineers must have the ability to design and a facility to communicate their design intentions. Where you are required to list and discuss possible structural solutions you must show by brief, clear, logical and systematic presentation that you understand the general structural engineering principles involved.

In selecting and developing your design you should also remember the guidance given in the Institution's report, Structural design - achieving excellence, and in particular:

- 1) "the structure must be safe",
- 2) "a good design has certain typical features – simplicity, unity and necessity",
- 3) "the structure must fulfil its intended function".

If you have difficulty in deciding the correct interpretation of a question, pay particular attention to point 6. notes to candidates, on the front cover. The examiners will take into account your interpretation – and the design you base on this – if this is clearly stated at the beginning of your answer.

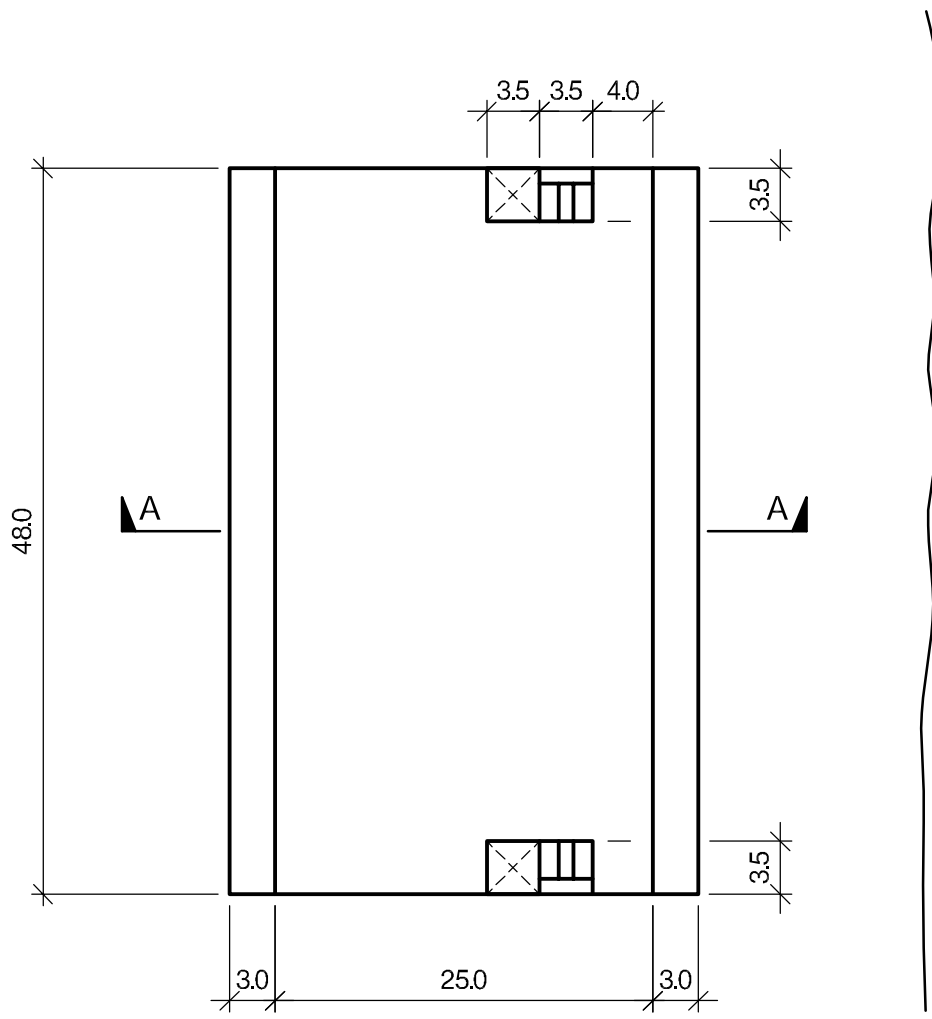
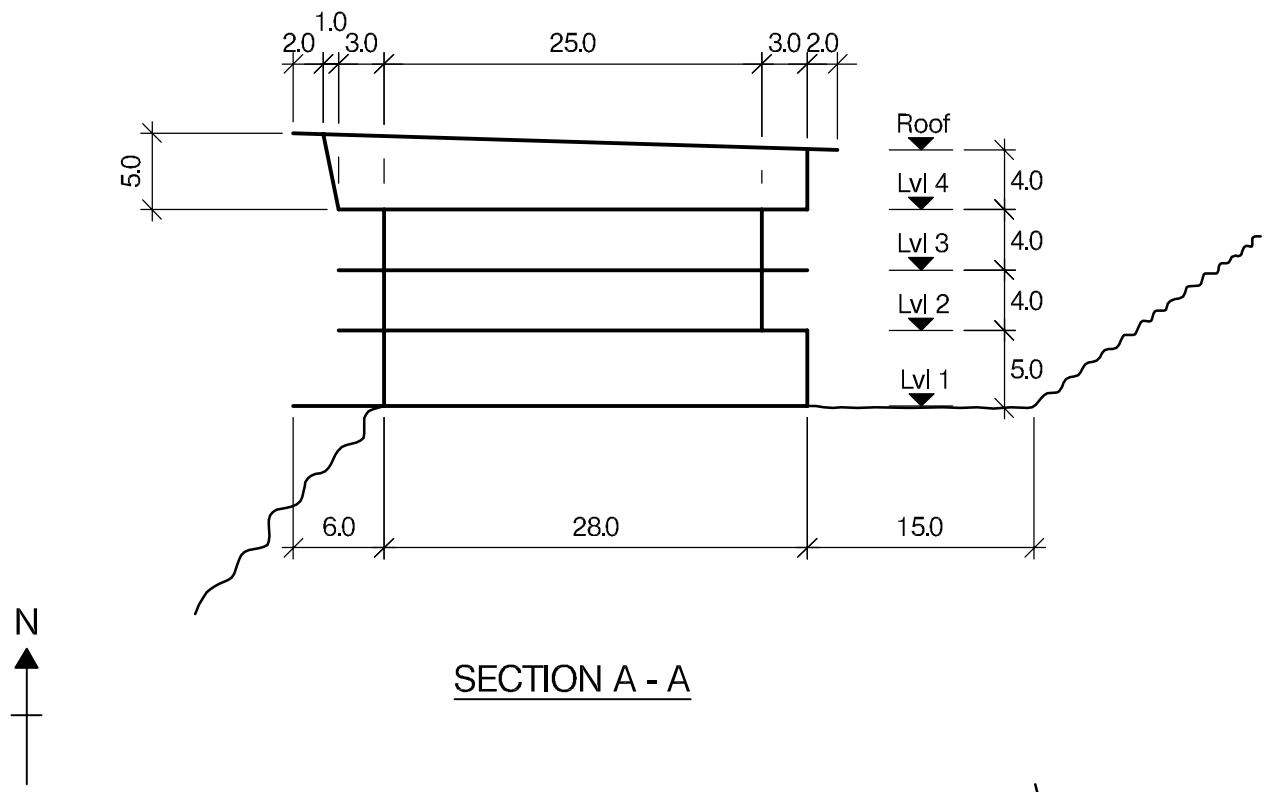

NOTE: All dimensions are in metres

**FIGURE Q1**

# Question 1. Proposed new hotel with apartments

## Client's requirements

1. A new four storey hotel building with apartments overlooking a picturesque gorge. See Fig 1
2. The building is to be located on the edge of a rock shelf and has a 15.0m access road to the rear.
3. The external elevations of the building are to be clad in a lightweight insulated material and are to be fully glazed on the West and East elevations.
4. The roof is to accommodate solar panelling.
5. A total of 42 apartments are required with 14 on each of Levels 2 and 3, each measuring 6.0m wide x 11.0m long and 14 at Level 4 measuring 6.0m wide x 14.0m long. Each apartment is accessed by a central corridor on each floor 3.0m wide.
6. The area at Level 1 is to accommodate a lounge, restaurant, bar office and a reception.
7. The clear internal floor to ceiling height in each apartment is to be 3.0m, and a clear internal floor to ceiling height at Level 1 of 4.0m.
8. A maximum of one row of columns is permitted internally and the columns are to be at a minimum spacing of 5.0m.
9. The rock up to 1.0m back from the rock face is highly weathered and cannot be relied up to carry structural loads.

## Imposed loading

- |                             |                      |
|-----------------------------|----------------------|
| 10. Roof and apartments     | 2.0kN/m <sup>2</sup> |
| 11. Level 1, Reception area | 4.0kN/m <sup>2</sup> |

## Site conditions

12. The site is located in a hilly location at 1000m altitude. Basic wind speed is 49.0m/s based on a 3-second gust; the equivalent mean hourly wind speed is 24.5m/s.
13. Ground conditions across the construction plateau:

Ground level -1.4m	Top soil / loose shale
Below 1.4m	Weathered rock - allowable bearing pressure 600kN/m <sup>2</sup>
No groundwater was encountered.	

## Omit from consideration

14. Detail design of the lift a stairs.

## SECTION 1

**(50 marks)**

- a. Prepare a design appraisal with appropriate sketches indicating two distinct and viable solutions for the proposed structure including foundations. Indicate clearly the functional framing, load transfer, serviceability and stability aspects of each scheme. Review and critically appraise the schemes and identify the solution you recommend, giving reasons for your choice. (40 marks)
- b. After the hotel has been open for a year and has been shown to be a commercial success, the client wishes to add an open-air swimming pool 1.2m deep and 10.0m x 5.0m plan area to the centre of the roof. Write a letter to the client explaining how this could be achieved. (10 marks)

## SECTION 2

**(50 marks)**

For the solution recommended in Section 1(a)

- c. Prepare sufficient design calculations to establish the form and size of all the principal structural elements including the foundations. (20 marks)
- d. Prepare general arrangement drawings, which may include plans, sections and elevations to show the dimensions, layout and disposition of the structural elements and critical details for estimating purposes. (20 marks)
- e. Prepare a detailed method statement for the safe construction of the works and an outline construction programme. (10 marks)

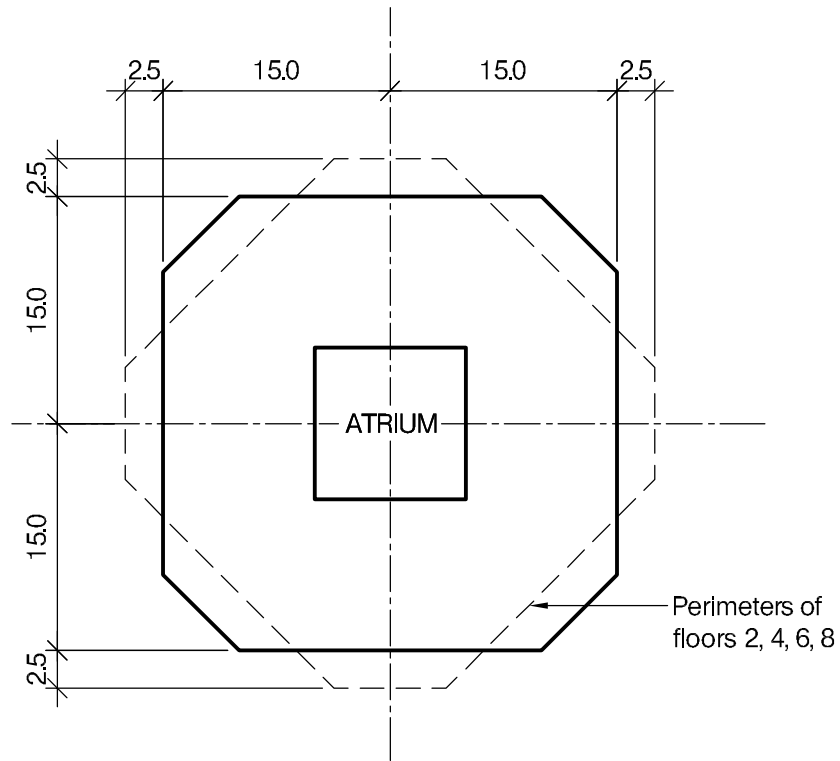

PLAN (Levels 3, 5, 7)

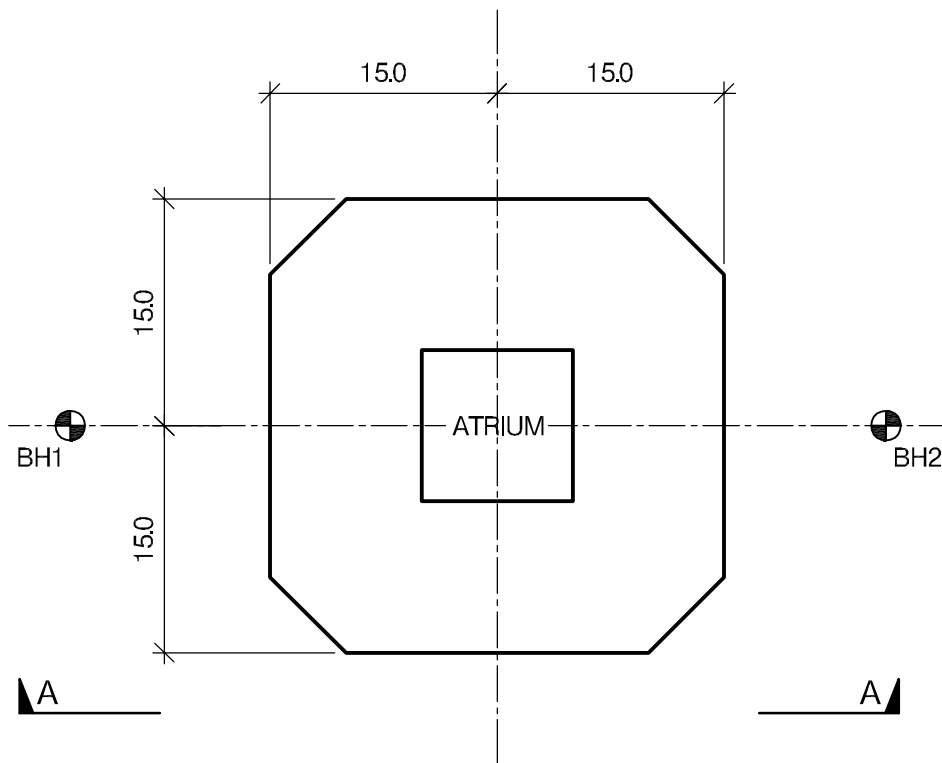

PLAN (Levels 1 to 2)

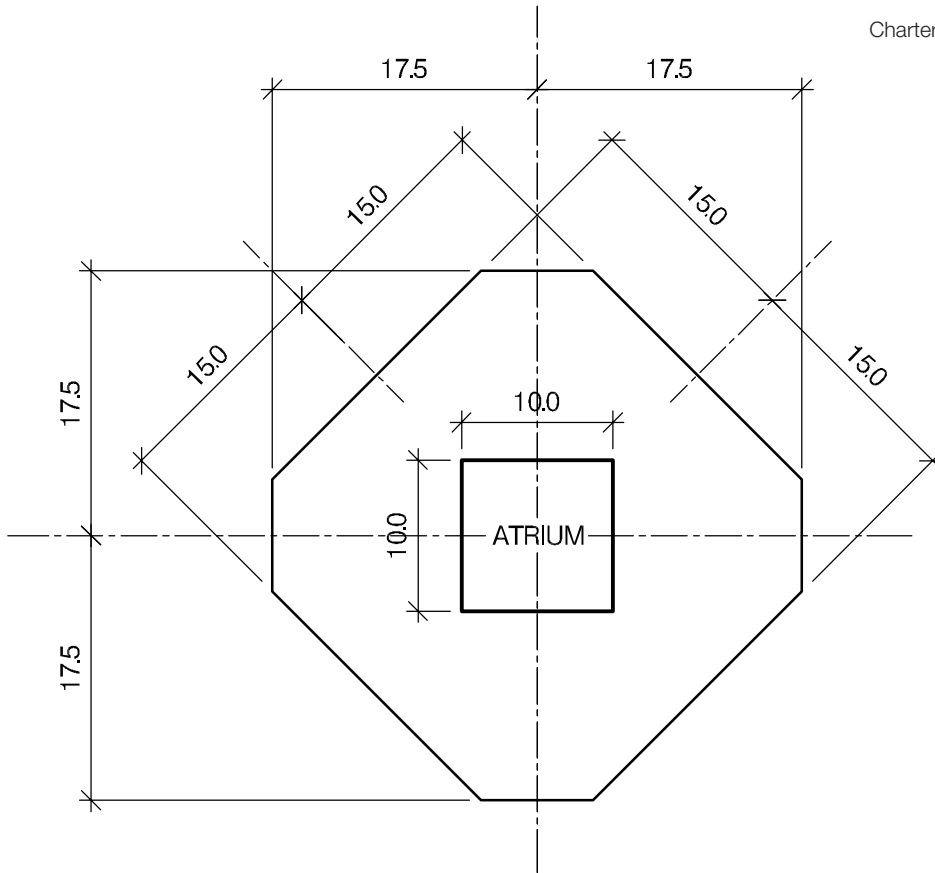

PLAN (Levels 2, 4, 6, 8)

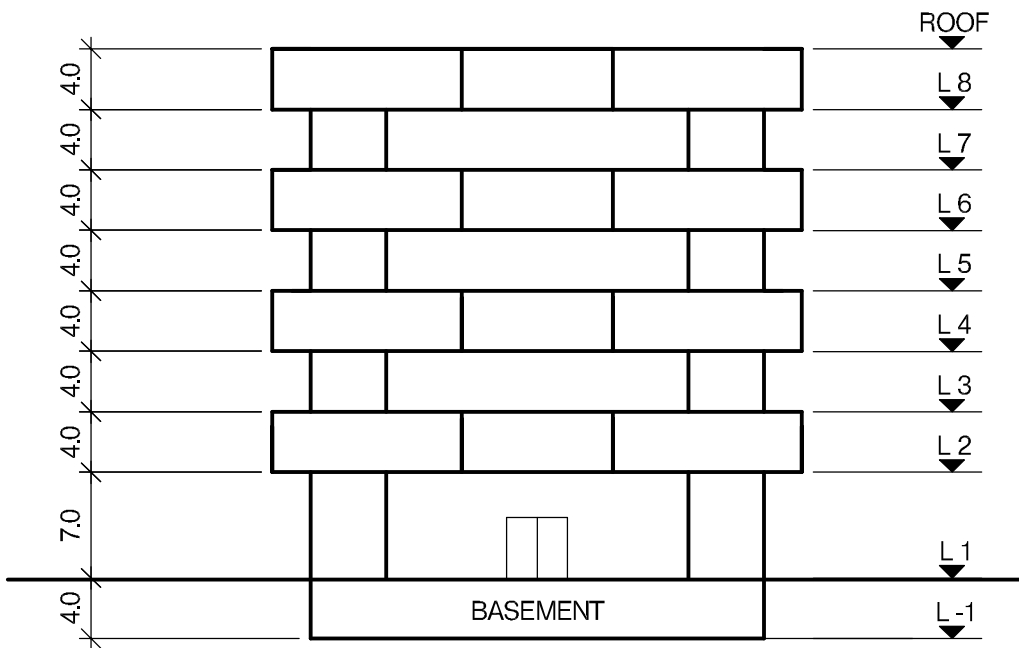

ELEVATION A - A

NOTE: All dimensions are in metres

FIGURE Q2 - 2

**BLANK PAGE**



## Question 2. Headquarters Office Building

### Client's requirements

1. An eight storey office building with single level basement for car parking and a central atrium; see Figure Q2. The building will be the new Headquarters for a company, and an open plan design is intended. The footprint of the building is square with corners cut back. Successive floors are rotated in plan by 45 degrees from the one below; see Figure Q2.
2. All elevations are to be clad in curtain wall glazing. Columns and floors are to be visible through the curtain walling. External columns are not permitted.
3. All floors including the basement are to have a 4.0m clear floor to floor height, except level 1 where 7m is required. A 0.5m zone is required for ceiling and services for all floors and basement. Floor to ceiling height is to be as large as possible.
4. The central atrium is to incorporate two lifts and staircases. The roof is to be flat with perimeter safety handrailing and a glazed roof over the atrium.
5. The basement is to accommodate a plant room of area 50.0m<sup>2</sup>

### Imposed loading

- |             |   |
|-------------|---|
| 6. Roof     | 0.75kN/m <sup>2</sup>   |
| 7. Offices  | 2.5kN/m <sup>2</sup> plus 1.0kN/m <sup>2</sup> for partitions |
| 8. Basement | 2.5kN/m <sup>2</sup> (15.0kN/m <sup>2</sup> for plant room)   |

### Site conditions

9. The site is located on the outskirts of a large town. Basic wind speed is 40.0m/s based on a 3-second gust; the equivalent mean hourly speed is 20.0m/s.
10. Ground conditions vary across the site:

Borehole 1:	Ground level – 1.0m	Top soil (not solid)
	1.0 - 6.0m	Medium dense to dense Sand. N values increase linearly with depth from 20 to 60
	Below 6.0m	Stiff clay C = 300kN/m <sup>2</sup>
Borehole 2:	Ground level - 1.0m	Top soil (not solid)
	1.0 - 3.0m	Firm clay C = 75kN/m <sup>2</sup>
	3.0 - 6.0m	Medium dense to dense Sand. N values increase linearly with depth from 20 to 60
	Below 6.0m	Stiff clay C = 300kN/m <sup>2</sup>

Groundwater was encountered at 3.5m below ground level.

### Omit from consideration

11. Design of lift and stairs, atrium roof and parking layout.

### SECTION 1

**(50 marks)**

- a. Prepare a design appraisal with appropriate sketches indicating two distinct and viable solutions for the proposed structure including foundations. Indicate clearly the functional framing, load transfer, serviceability and stability aspects of each scheme. Review and critically appraise the schemes, and identify the scheme you recommend giving reasons for your choice. (40 marks)
- b. After the scheme design is complete, the Client asks if the plant room can be placed on the roof to provide more parking spaces in the basement. Write a letter to the Client explaining the implications on your design and the construction and any recommendations. (10 marks)

### SECTION 2

**(50 marks)**

For the solution recommended in Section 1(a)

- c. Prepare sufficient design calculations to establish the form and size of all the principal structural elements including the foundations. (20 marks)
- d. Prepare general arrangement drawings, which may include plans, sections and elevations, to show the dimensions, layout and disposition of the structural elements and critical details for estimating purposes. (20 marks)
- e. Prepare a detailed method statement for the safe construction of the works and an outline construction programme to include consideration of any temporary works that may be required. (10 marks)

(10 marks)

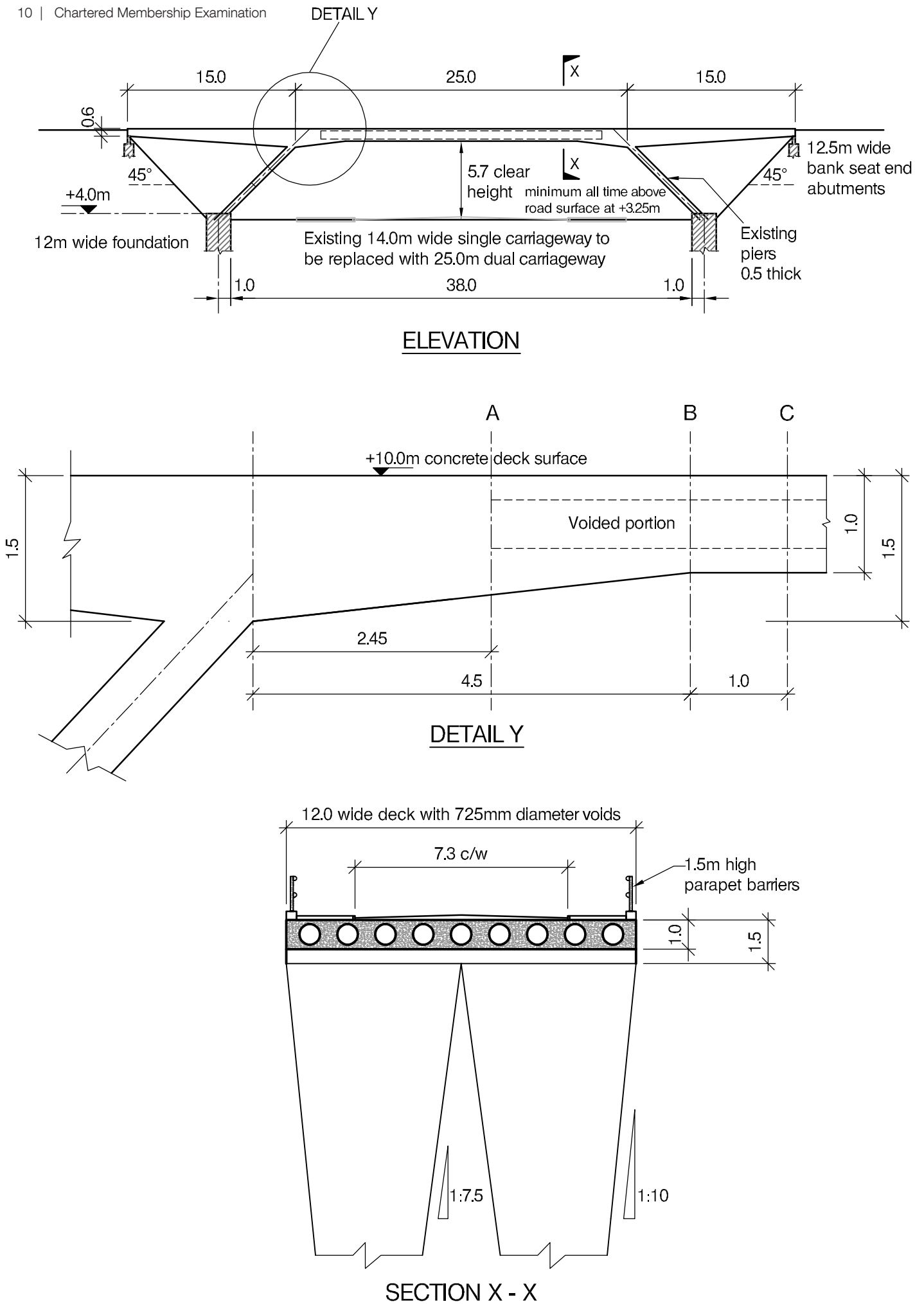

NOTE: All dimensions are in metres

**FIGURE Q3**

## Question 3 – Replacement Bridge over a Highway

### Client's requirements

1. An existing 55m long three span standard reinforced concrete bridge needs immediate replacement. Existing bridge dimensions and details are provided in Figure Q3. The replacement bridge must use the existing end abutments. The foundation bases for the intermediate inclined piers may also be used.
2. The existing bridge must remain in use Monday to Friday throughout the year except for one week in April and one week in December.
3. The existing carriageway, footways and parapets must be replaced to the same dimensions. The arrangement of spans could be altered if needed.
4. The original bridge was built on a weak rock cutting and it is essential that the new bridge does not exceed the original bridge width and the bearing capacity of its foundations.
5. The highway carriageway under the superstructure must maintain 5.7m clearance. The replacement bridge is expected to be aesthetically pleasing.

### Imposed loading

6. Footways      5.0kN/m<sup>2</sup>
7. Carriageway    10.0N/m<sup>2</sup>

### Site conditions

6. The site is in a rural area. Basic wind speed is 46.0m/s based on a 3-second gust; the equivalent mean hourly wind speed is 23.0m/s.
7. Ground conditions: weak rock, safe bearing capacity 1,000kN/m<sup>2</sup>.

### Omit from consideration

8. Design against loads from vehicle impact.

## SECTION 1

**(50 marks)**

- a. Prepare a design appraisal with appropriate sketches indicating two distinct and viable solutions for the proposed structure. Indicate clearly the functional framing, load transfer, serviceability, and stability aspects of each scheme. Review and critically appraise the schemes. Identify the solution you recommend, giving reasons for your choice. (40 marks)
- b. After completion of the design the Client informs you that the highway below the bridge is to be widened to 40m instead of 25m. Write a letter to the Client advising them on the implications on the design. (10 marks)

## SECTION 2

**(50 marks)**

For the solution recommended in Section 1(a)

- c. Prepare sufficient design calculations to establish the form and size of all the principal structural elements including the foundations. (20 marks)
- d. Prepare general arrangement drawings which may include plans, sections and elevations to show the dimensions, layout and disposition of the structural elements and critical details for estimating purposes. (20 marks)
- e. Prepare a detailed method statement for the safe construction of the works and an outline construction program to include consideration of any temporary works that may be required. (10 marks)

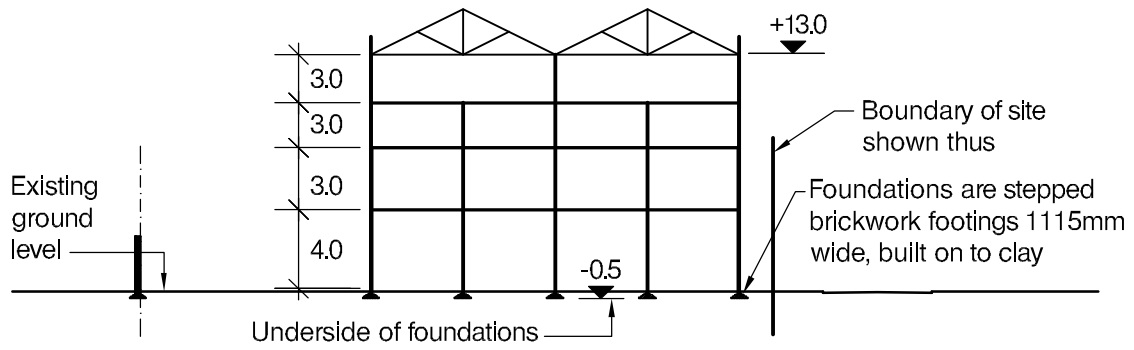

**SECTION THROUGH EXISTING WAREHOUSE**

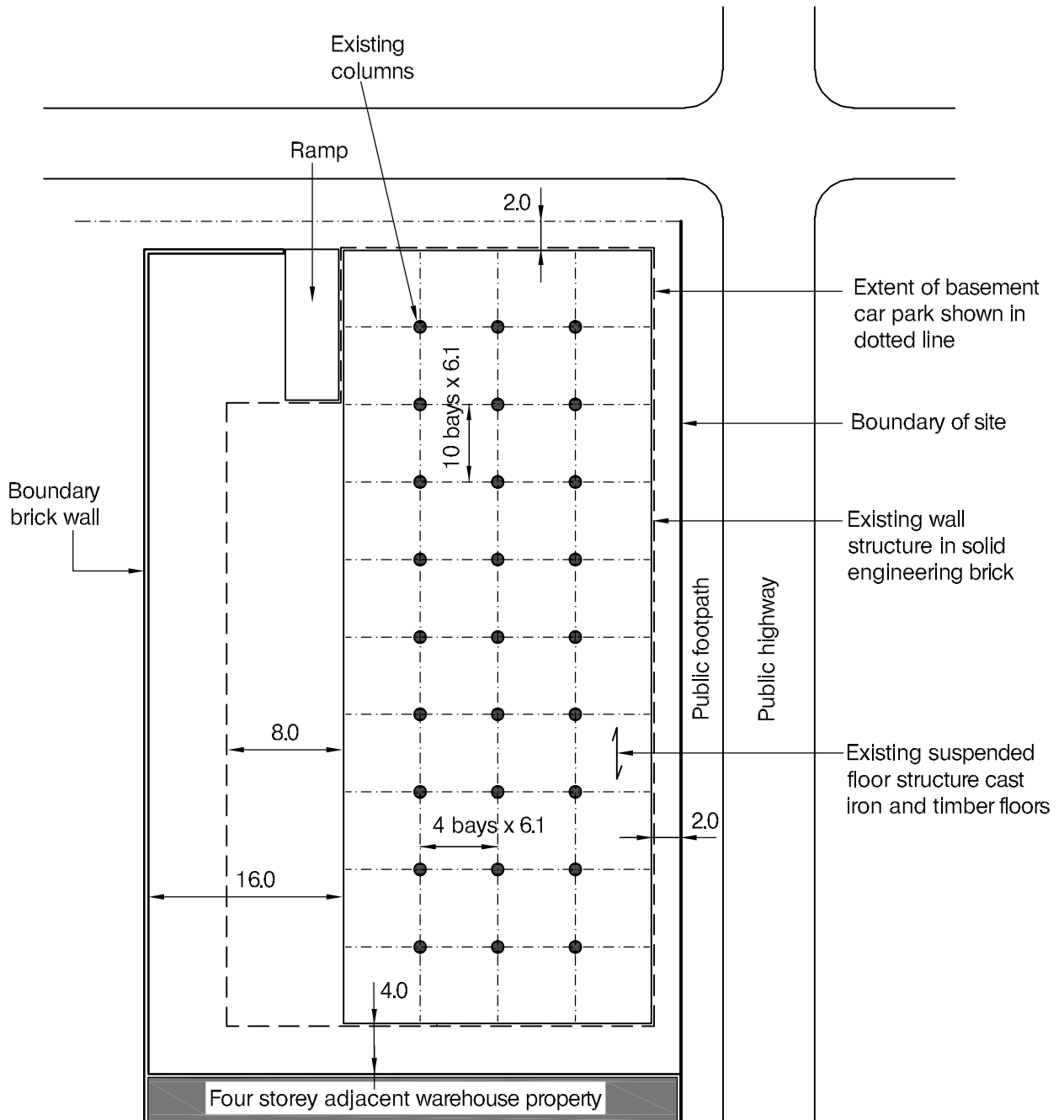

**PLAN ON WAREHOUSE SITE**

NOTE: All dimensions are in metres

**FIGURE Q4**

# Question 4 - Underground Car Park

## Client's requirements

1. An existing Victorian warehouse is to be converted to apartments, and an underground car park added. The building stands on a city centre plot which abuts public highways on two sides, a masonry perimeter wall on one side, and another masonry warehouse on the fourth. See Figure Q4.
2. The existing structure is in good condition and in previous use floor loads in excess of  $5.0\text{kN/m}^2$  were applied.
3. A new lift and staircase are required which will serve all storeys of the new building.
4. The underground car park must achieve the clear dimensions shown in Figure Q4, and a clear headroom of 3.5m.

## Imposed loading

- |                    |                     |
|--------------------|---------------------|
| 5. Roof            | $0.75\text{kN/m}^2$ |
| 6. Apartment floor | $2.5\text{kN/m}^2$  |
| 7. Car park floor  | $2.5\text{kN/m}^2$  |

## Site conditions

8. The site is located in a city centre. The basic wind speed is  $46.0\text{m/s}$  based on a 3-second gust; the equivalent mean hourly wind speed is  $23.0\text{m/s}$ .
9. Ground conditions:

Ground level – 0.3m	Made ground
0.3 - 12.2m	Clay, firm becoming very firm with depth. At 4.0m $C=70\text{kN/m}^2$ , at 8.0m $C=140\text{kN/m}^2$
Below 12.2m	Friable mudstone, compressive strength $650\text{ kN/m}^2$

No groundwater was encountered.

## Omit from consideration

10. Detailed assessment of the existing warehouse structure.
11. Access ramp to car park.

## SECTION 1

**(50 marks)**

- a. Prepare a design appraisal with appropriate sketches indicating two distinct and viable solutions for the proposed structure including the foundations. Indicate clearly the functional framing, load transfer, serviceability, and stability aspects of each scheme. Review and critically appraise the schemes, and identify the solution you recommend, giving reasons for your choice. (40 marks)
- b. Prior to construction the client asks whether it would be possible to add an additional storey to the building. Write a letter to the client addressing the viability of adding a floor, and the impact on the current design. (10 marks)

## SECTION 2

**(50 marks)**

For the solution recommended in Section 1(a)

- c. Prepare sufficient design calculations to establish the form and size of all the principal structural elements including the foundations. (20 marks)
- d. Prepare general arrangement drawings which may include plans, sections and elevations to show the dimensions, layout and disposition of the structural elements and critical details for estimating purposes. (20 marks)
- e. Prepare a pictorial outline construction sequence showing how the basement car park is to be constructed, detailing any temporary works which are necessary for the safe completion of the work. (10 marks)

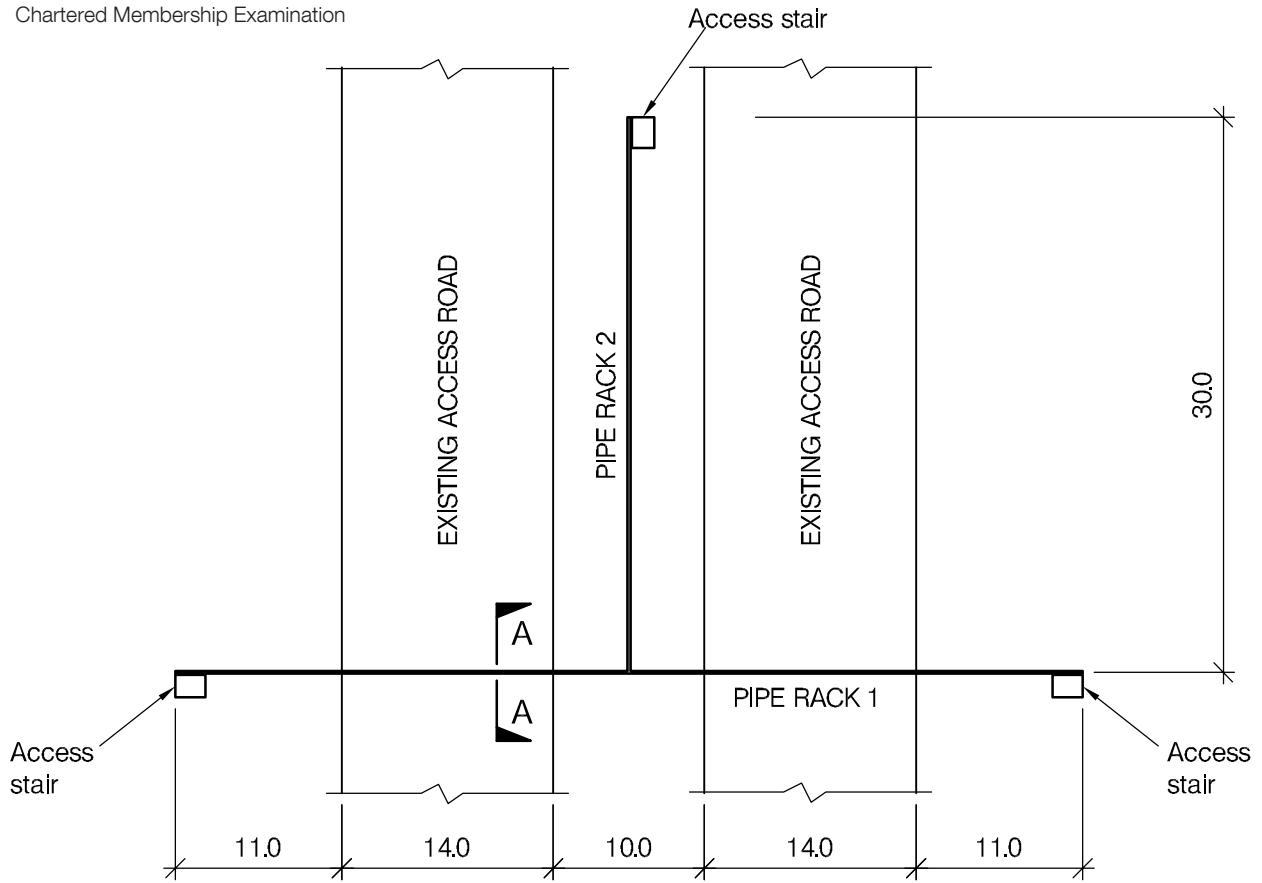

PLAN

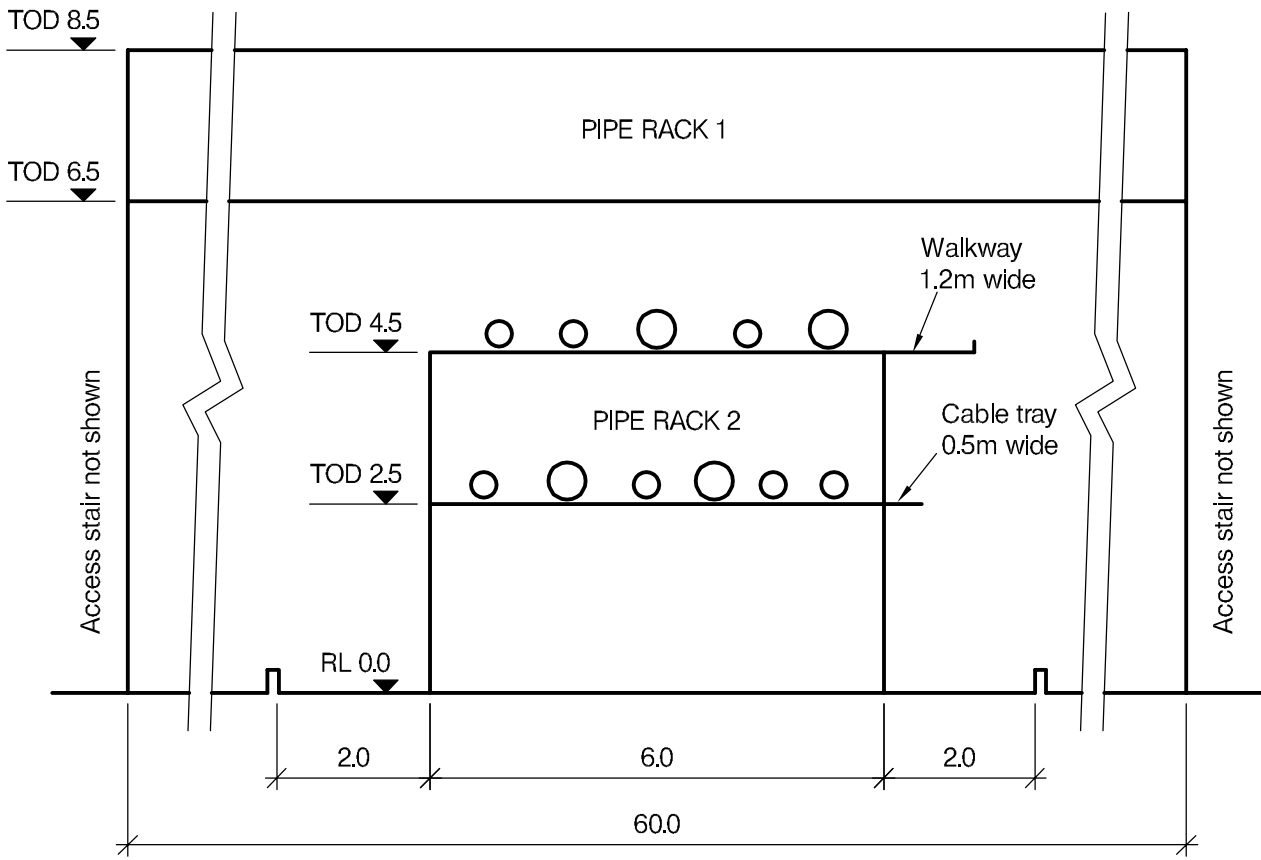

(TOD : Top of Deck)

ELEVATION

NOTE: All dimensions are in metres

FIGURE Q5 - 1

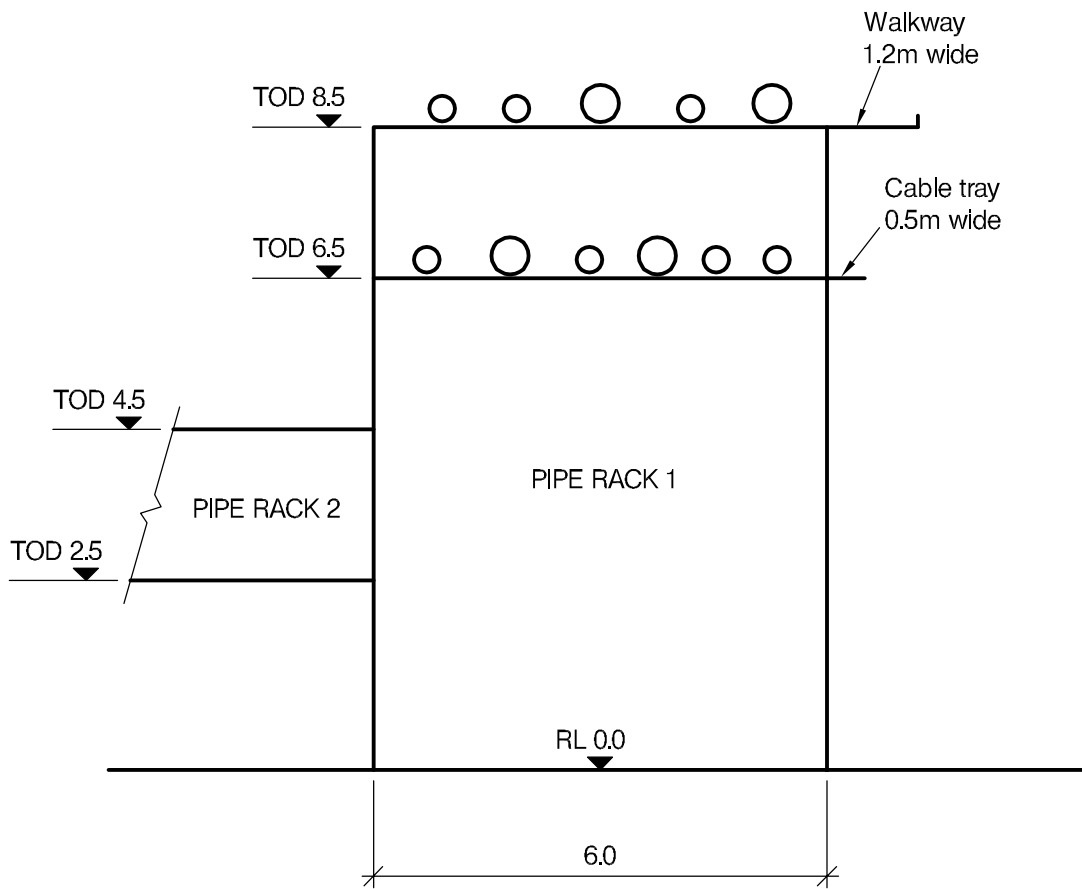

SECTION A - A

## Question 5 - Piperack

### Client's requirements

- Two sets of piperacks are required to support two decks of pipes, mechanical equipment, and 0.5m cable tray with a 1.2m-wide walkway in an industrial processing plant over an existing road as shown in Figure Q5.
- The piperacks shall be designed to resist the horizontal transverse forces expected. Such forces may be induced by friction or thermal movements and are provided in the imposed loading below.
- All the pipes to be installed are capable of spanning 8.0m without support. The pipes may be assumed to have a maximum external diameter of 1.0m including insulation.
- No load may be imposed on the staircase access structures by the piperacks.
- Where piperack 1 crosses over the existing roads, a minimum height clearance of 6.0m is required.

### Imposed loading

- Piperacks: 2.0kN/m<sup>2</sup> per deck including contents, weight of pipes plus fittings, valves, insulation, mechanical equipment
- Walkway: 2.5kN/m<sup>2</sup> plus a point load 4.5kN within any span
- Cable tray: 1.0kN/m<sup>2</sup> including cable ladder weight
- Pipe friction and thermal loads: 20% of gravitational loads in both horizontal directions and 10% in vertical direction

### Site conditions

- The site is located in a remote area. Basic wind speed is 80 m/s based on a 3-second gust; the equivalent mean hourly wind speed is 40 m/s.
- Ground conditions:

Ground level to 0.5m	Top soil
0.5m - 5.0m	Sand and gravel N = 20
5.0m - 10.0m	Sand and gravel N = 30
Below 10.0m	Limestone, safe bearing pressure 1,500kN/m <sup>2</sup>

### Omit from consideration

- Detailed design of staircase access
- Detail of tie in and inter access decks

## SECTION 1

**(50 marks)**

- Prepare a design appraisal with appropriate sketches indicating two distinct and viable solutions for the proposed structure including the foundations. Indicate clearly the functional framing, load transfer, serviceability, and stability aspects of each scheme. Review and critically appraise the schemes, and identify the solution you recommend, giving reasons for your choice. (40 marks)
- After the design has been completed the client advises that the entire structure will be fabricated in the workshop and delivered to site with maximum 12m length modules to minimize site work. Write a letter to the Client explaining the implication on your design. (10 marks)

## SECTION 2

**(50 marks)**

For the solution recommended in Section 1(a)

- Prepare sufficient design calculations to establish the form and size of all the principal structural elements including the foundations. (20 marks)
- Prepare general arrangement drawings which may include plans, sections and elevations to show the dimensions, layout and disposition of the structural elements and critical details for estimating purposes. (20 marks)
- Prepare a detailed method statement for the safe construction of the structure and an outline construction programme. (10 marks)



**BLANK PAGE**

**BLANK PAGE**

**BLANK PAGE**

---

International HQ,  
47-58 Bastwick Street,  
London EC1V 3PS, UK

---

**T** +44 (0)20 7235 4535  
**E** membership@istructe.org

---

**[www.istructe.org](http://www.istructe.org)**

---